

# S-7300A

# INSTRUCTION MANUAL

---

Please read this manual before using the machine.  
Please keep this manual within easy reach for quick reference.

---

SINGLE NEEDLE DIRECT DRIVE LOCK STITCHER WITH  
ELECTRONIC FEEDING SYSTEM AND THREAD TRIMMER

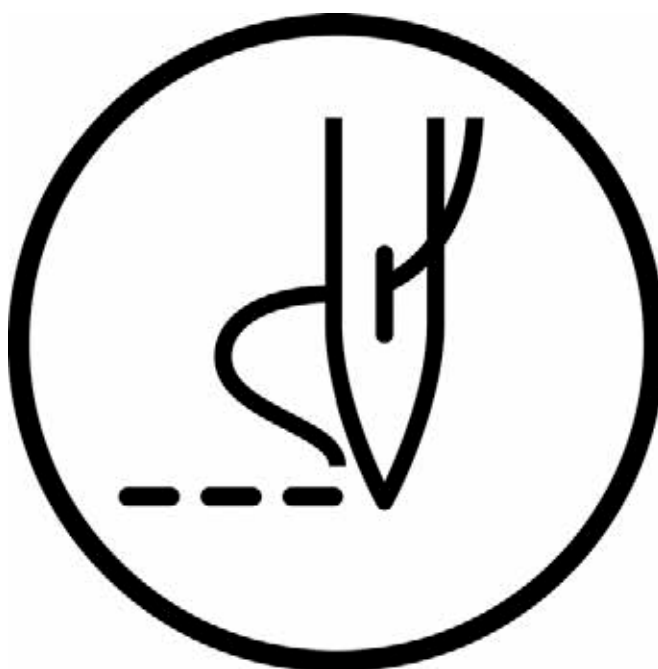

---

**brother**

Thank you very much for buying a BROTHER sewing machine. Before using your new machine, please read the safety instructions and the explanations given in the instruction manual.



With industrial sewing machines, it is normal to carry out work while positioned directly in front of moving parts such as the needle and thread take-up, and consequently there is always a danger of injury that can be caused by these parts. Follow the instructions from training personnel and instructors regarding safe and correct operation before operating the machine so that you will know how to use it correctly.

# SAFETY INSTRUCTIONS

## [1] Safety indications and their meanings

This instruction manual and the indications and symbols that are used on the machine itself are provided in order to ensure safe operation of this machine and to prevent accidents and injury to yourself or other people. The meanings of these indications and symbols are given below.

### Indications

 <b>DANGER</b>	The instructions which follow this term indicate situations where failure to follow the instructions will result in death or serious injury.
 <b>WARNING</b>	The instructions which follow this term indicate situations where failure to follow the instructions could result in death or serious injury.
 <b>CAUTION</b>	The instructions which follow this term indicate situations where failure to follow the instructions may result in minor or moderate injury.

### Symbols



..... This symbol (  ) indicates something that you should be careful of. The picture inside the triangle indicates the nature of the caution that must be taken.  
(For example, the symbol at left means “beware of injury”.)



..... This symbol (  ) indicates something that you must not do.



..... This symbol (  ) indicates something that you must do. The picture inside the circle indicates the nature of the thing that must be done.  
(For example, the symbol at left means “you must make the ground connection”.)

## [2] Notes on safety

### DANGER



Wait at least 5 minutes after turning off the power switch and disconnecting the power cord from the wall outlet before opening the cover of the control box. Touching areas where high voltages are present can result in severe injury.

### WARNING



Do not allow any liquids to get onto this sewing machine, otherwise fire, electric shocks or operating problems may occur.



If any liquid gets inside the sewing machine (machine head or control box), immediately turn off the power and disconnect the power plug from the electrical outlet, and then contact the place of purchase or a qualified technician.

### CAUTION

#### Environmental requirements



Use the sewing machine in an area which is free from sources of strong electrical noise such as electrical line noise or static electric noise. Sources of strong electrical noise may cause problems with correct operation.



Any fluctuations in the power supply voltage should be within  $\pm 10\%$  of the rated voltage for the machine. Voltage fluctuations which are greater than this may cause problems with correct operation.



The power supply capacity should be greater than the requirements for the sewing machine's power consumption. Insufficient power supply capacity may cause problems with correct operation.



The ambient temperature should be within the range of 5°C to 35°C during use. Temperatures which are lower or higher than this may cause problems with correct operation.



The relative humidity should be within the range of 45% to 85% during use, and no dew formation should occur in any devices. Excessively dry or humid environments and dew formation may cause problems with correct operation.



In the event of an electrical storm, turn off the power and disconnect the power cord from the wall outlet. Lightning may cause problems with correct operation.



Do not connect anything to the USB port other than the USB memory. If this is not observed, problems with operation may result.

#### Installation



Machine installation should only be carried out by a qualified technician.



Contact your Brother dealer or a qualified electrician for any electrical work that may need to be done.



The sewing machine weighs approximately 34.5 kg (76lb). The installation should be carried out by two or more people.



Do not connect the power cord until installation is complete. The machine may operate if the treadle is depressed by mistake, which could result in injury.



Turn off the power switch before inserting or removing the plug, otherwise damage to the control box could result.



Be sure to connect the ground. If the ground connection is not secure, you run a high risk of receiving a serious electric shock, and problems with correct operation may also occur.



When securing the cords, do not bend the cords excessively or fasten them too hard with staples, otherwise there is the danger that fire or electric shocks could occur.



If using a work table which has casters, the casters should be secured in such a way so that they cannot move.



Secure the table so that it will not move when tilting back the machine head. If the table moves, it may crush your feet or cause other injuries.



Use both hands to hold the machine head when tilting it back or returning it to its original position. If only one hand is used, the weight of the machine head may cause your hand to slip, and your hand may get caught.



Be sure to wear protective goggles and gloves when handling the lubricating oil and grease, so that they do not get into your eyes or onto your skin, otherwise inflammation can result.

Furthermore, do not drink the oil or eat the grease under any circumstances, as they can cause vomiting and diarrhea.

Keep the oil out of the reach of children.



# CAUTION

## Sewing



This sewing machine should only be used by operators who have received the necessary training in safe use beforehand.



The sewing machine should not be used for any applications other than sewing.



Be sure to wear protective goggles when using the machine.

If goggles are not worn, there is the danger that if a needle breaks, parts of the broken needle may enter your eyes and injury may result.



Turn off the power switch at the following times. The machine may operate if the treadle is depressed by mistake, which could result in injury.

- When threading the needle
- When replacing the bobbin and needle
- When not using the machine and when leaving the machine unattended



If using a work table which has casters, the casters should be secured in such a way so that they cannot move.



Attach all safety devices before using the sewing machine. If the machine is used without these devices attached, injury may result.



Do not touch any of the moving parts or press any objects against the machine while sewing, as this may result in personal injury or damage to the machine.



Secure the table so that it will not move when tilting back the machine head. If the table moves, it may crush your feet or cause other injuries.



Use both hands to hold the machine head when tilting it back or returning it to its original position. If only one hand is used, the weight of the machine head may cause your hand to slip, and your hand may get caught.



If an error occurs in machine operation, or if abnormal noises or smells are noticed, immediately turn off the power switch. Then contact your nearest Brother dealer or a qualified technician.



If the machine develops a problem, contact your nearest Brother dealer or a qualified technician.



Do not hold the machine head by the panel when tilting it back or returning it to its original position. If this is not observed, it may result in serious injury or damage to the sewing machine.

## Cleaning



Turn off the power switch before carrying out cleaning. The machine may operate if the treadle is depressed by mistake, which could result in injury.



Secure the table so that it will not move when tilting back the machine head. If the table moves, it may crush your feet or cause other injuries.



Use both hands to hold the machine head when tilting it back or returning it to its original position. If only one hand is used, the weight of the machine head may cause your hand to slip, and your hand may get caught.



Be sure to wear protective goggles and gloves when handling the lubricating oil and grease, so that they do not get into your eyes or onto your skin, otherwise inflammation can result.

Furthermore, do not drink the oil or eat the grease under any circumstances, as they can cause vomiting and diarrhea.

Keep the oil out of the reach of children.



Do not hold the machine head by the panel when tilting it back or returning it to its original position. If this is not observed, it may result in serious injury or damage to the sewing machine.

# CAUTION

## Maintenance and inspection



Maintenance and inspection of the sewing machine should only be carried out by a qualified technician.



Ask your Brother dealer or a qualified electrician to carry out any maintenance and inspection of the electrical system.



Turn off the power switch and disconnect the power cord from the wall outlet at the following times, otherwise the machine may operate if the treadle is depressed by mistake, which could result in injury.

- When carrying out inspection, adjustment and maintenance
- When replacing consumable parts such as the rotary hook and knife



Always be sure to turn off the power switch and then wait one minute before opening the pulley cover. If you touch the surface of the motor, it may cause burns.



If the power switch needs to be left on when carrying out some adjustment, make sure that you switch the sewing machine to maintenance mode. Pay careful attention to safety.



Secure the table so that it will not move when tilting back the machine head. If the table moves, it may crush your feet or cause other injuries.



Use both hands to hold the machine head when tilting it back or returning it to its original position. If only one hand is used, the weight of the machine head may cause your hand to slip, and your hand may get caught.



When replacing parts and installing optional accessories, be sure to use only genuine Brother parts. Brother will not be held responsible for any accidents or problems resulting from the use of non-genuine parts.



If any safety devices have been removed, be absolutely sure to re-install them to their original positions and check that they operate correctly before using the machine.



To prevent accidents and problems, do not modify the machine yourself. Brother will not be held responsible for any accidents or problems resulting from modifications made to the machine.



Do not hold the machine head by the panel when tilting it back or returning it to its original position. If this is not observed, it may result in serious injury or damage to the sewing machine.

### [3] Warning labels

The following warning labels appear on the sewing machine. Please follow the instructions on the labels at all times when using the machine. If the labels have been removed or are difficult to read, please contact your nearest Brother dealer.

1

	<b>▲ 危険</b> 高電圧部分に触れて、大けがをすることがある。 電源を切り、5分たってからカバーをはずすこと	<b>▲ 危険</b> 觸電高電圧部分 会導致受傷 左切斷電源5分後 再開啟蓋蓋
<b>▲ DANGER</b>	<b>▲ GEFAHR</b>	<b>▲ DANGER</b>
Hazardous to life with electric shock. Turn off main switch and wait 5 minutes before opening the cover.	High-voltage electric discharge. Risk of serious injury. Turn off power and wait 5 minutes before touching above or other parts.	Unsuitable for people who are allergic to electric shock. Turn off power and wait 5 minutes before touching above or other parts.
<b>▲ PELIGRO</b>		
Unsuitable for people who are allergic to electric shock. Turn off power and wait 5 minutes before touching above or other parts.		Unsuitable for people who are allergic to electric shock. Turn off power and wait 5 minutes before touching above or other parts.

2 Touching areas where high voltages are present can result in severe injury. Turn off the power before opening the cover.

3

**CAUTION**  
Moving parts may cause injury.

Operate with safety devices\* installed.

Turn off the power before carrying out operations such as threading, changing the needle, bobbin, knives or hook, cleaning and adjusting.

\* Safety devices: (A) Finger guard  
(B) Thread take-up cover  
(C) pulley cover

4 Be careful not to get your hands caught when returning the machine head to its original position after it has been tilted.

5 Be careful to avoid injury from the moving thread take-up and pulley.

6 Do not hold. Problems with operation or injury may occur.

7 Be sure to connect the ground. If the ground connection is not secure, you run a high risk of receiving a serious electric shock, and problems with correct operation may also occur.

8 Direction of operation

9 **brother**  
Lubricating Oil for Machining

**▲ CAUTION**

Lubricating oil may cause inflammation to eye and skin.  
Wear protective glasses and gloves.

Swallowing oil can cause diarrhoea and vomiting.  
Do not swallow.

Keep away from children.  
**FIRST AID**  
Eye contact:  
-Rinse with plenty of cold water.  
-Seek medical help.  
Skin contact:  
-Wash with soap and water.  
If swallowed:  
-Seek medical help immediately

10 Do not place your hands inside the bottom cover. Problems with operation or injury may occur.

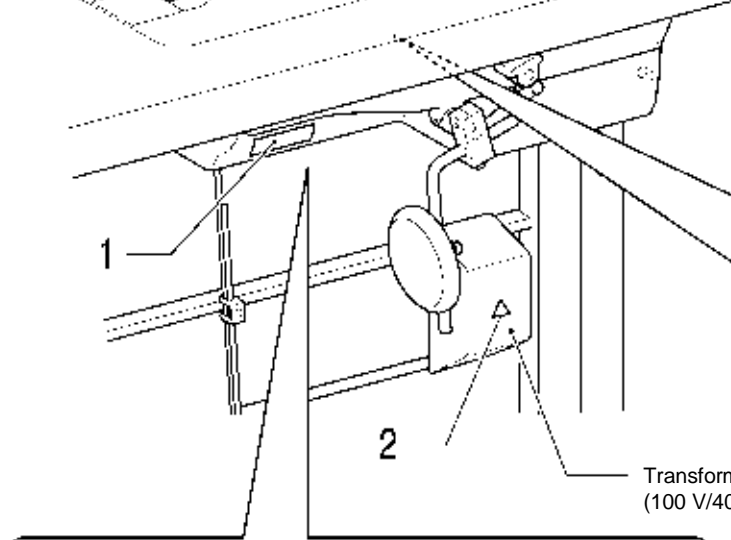
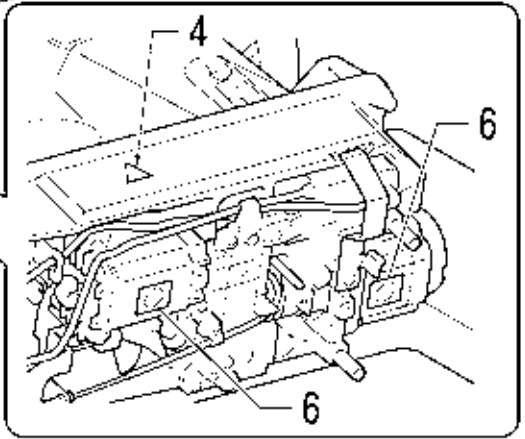
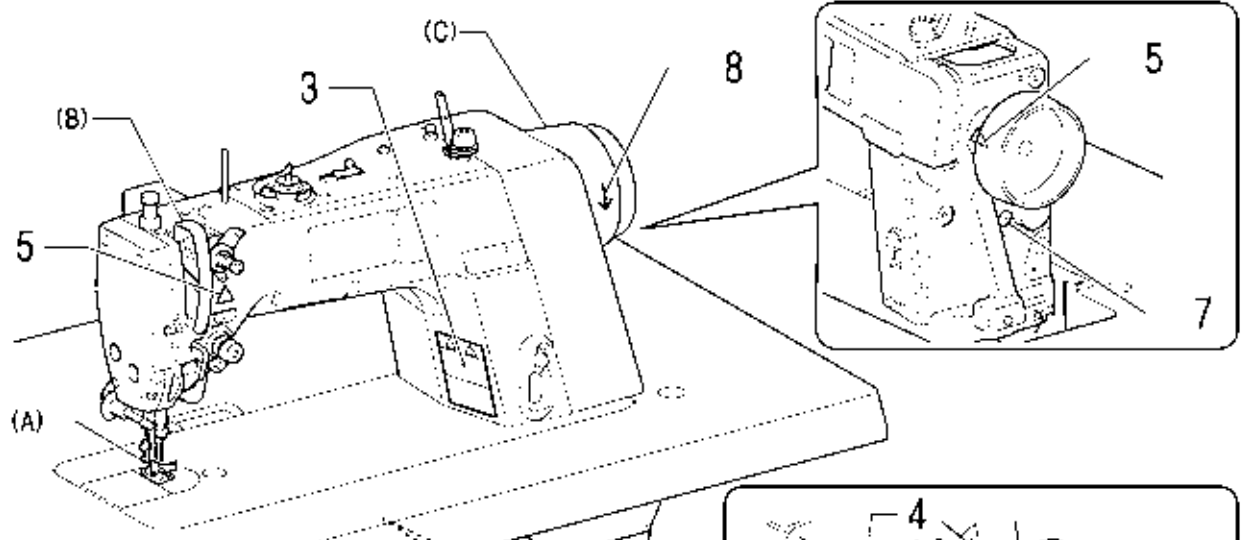

Transformer box  
(100 V/400 V system only)

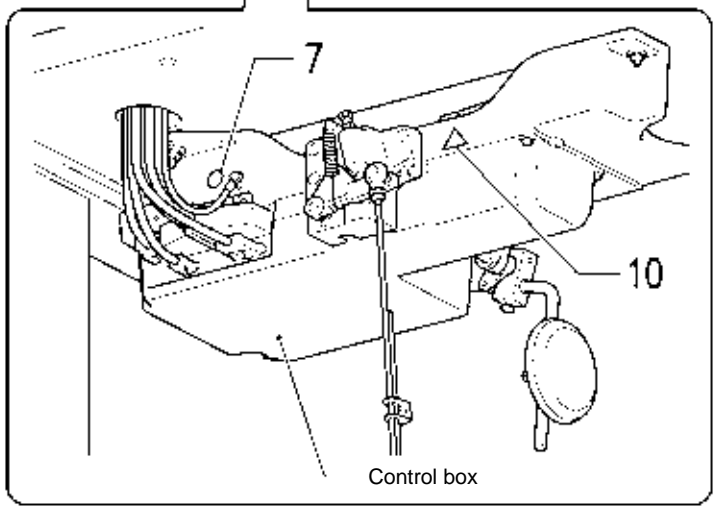

Control box

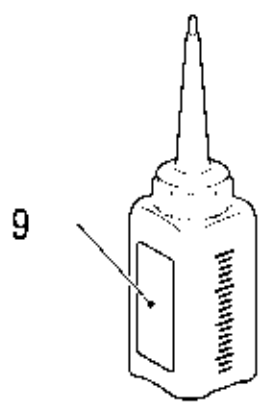

Oil tank





# CONTENTS

<b>1. MACHINE SPECIFICATIONS</b> .....	1
<b>2. NAMES OF MAJOR PARTS</b> .....	2
<b>3. INSTALLATION</b> .....	3
3-1. Table processing diagram .....	4
3-2. Installation .....	4
3-3. Lubrication .....	7
3-4. Connecting the cords.....	8
3-4-1. Connecting the cords .....	8
3-4-2. Other cords .....	10
3-5. Test operation (Operating the treadle) .....	14
3-6. Adjusting the treadle.....	15
<b>4. PREPARATION BEFORE SEWING</b> .....	16
4-1. Installing the needle.....	16
4-2. Removing the bobbin case.....	16
4-3. Winding the lower thread.....	17
4-4. Installing the bobbin case.....	17
4-5. Threading the upper thread.....	18
4-6. Using the knee lifter.....	19
<b>5. USING THE OPERATION PANEL (BASIC OPERATIONS)</b> .....	20
5-1. Names and functions.....	20
5-2. Home screen .....	20
5-2-1. Description of detailed home screen ...	21
5-2-2. Description of simple home screen.....	22
5-2-3. Types of icons.....	23
5-3. Menu screen.....	24
5-4. Program setting method .....	25
5-4-1. Program structure .....	25
5-4-2. Start backtack settings.....	28
5-4-3. Main sewing settings.....	29
5-4-4. End backtack settings .....	30
5-5. Using program individual functions and program common functions .....	31
5-5-1. Needle up/down .....	32
5-5-2. Thread trimming lock .....	32
5-5-3. Thread wiper .....	32
5-5-4. Correction sewing .....	33
5-5-5. AUTO .....	33
5-5-6. Slow start .....	34
5-5-7. Special locus.....	34
5-5-8. Best PFM mode .....	35
5-5-9. X-over seam assist mode .....	35
5-6. Using the production counter .....	36
5-7. Using the lower thread counter .....	37
5-8. Home screen mode setting .....	39
5-9. Illumination LED brightness setting .....	40
<b>6. USING THE OPERATION PANEL (ADVANCED OPERATIONS)</b> .....	41
6-1. Adding and deleting steps.....	41
6-2. Editing steps.....	42
6-3. Sewing start step setting.....	43
6-4. Program copy.....	44
6-5. Shortcut key assignment method .....	45
6-6. Design stitch registration method .....	46
6-7. Working pace setting method .....	48
6-8. Memory switch setting method (Standard) .....	49
6-9. List of memory switch settings .....	50
6-10. Hand switches.....	54
6-10-1. Hand switch function setting.....	56
6-10-2. 2nd correction pitch setting .....	57
6-10-3. 2nd pitch setting .....	57
6-11. Reading and writing data using USB media.....	58
6-12. Resetting all settings to their defaults .....	59
<b>7. SEWING</b> .....	60
7-1. Sewing .....	60
7-2. Using the thread wiper .....	60
7-3. Backtacking.....	61
7-4. Sewing condensed stitches .....	62
<b>8. NEW FUNCTIONS</b> .....	63
8-1. Best PFM mode (short trailing length/ bird's nest reduction mode).....	63
8-2. Using X-over seam assist mode .....	64
8-3. Using the feed dog locus .....	65
8-4. Example of using hand switch settings .....	66
<b>9. THREAD TENSION</b> .....	67
9-1. Adjusting the thread tension .....	67
9-2. Adjusting the presser foot pressure .....	68
9-3. Adjusting the trailing length after thread trimming .....	68
9-4. Adjusting the thread take-up amount (-[ ] [ ] 3 specifications).....	69
<b>10.CLEANING</b> .....	70
10-1. Daily cleaning procedures.....	70
<b>11.ADJUSTING THE ROTARY HOOK LUBRICATION AMOUNT</b> .....	72
<b>12.STANDARD ADJUSTMENTS</b> .....	73
12-1. Thread tension spring .....	73
12-2. Arm thread guide R.....	74
12-3. Presser foot height.....	75
12-4. X-over seam sensor correction .....	75

12-5. Adjusting the feed dog height.....	76
12-6. Adjusting the feed dog angle.....	77
12-7. Adjusting the needle bar height.....	78
12-8. Adjusting the needle and feed mechanism timing .....	79
12-9. Needle and rotary hook timing .....	80
12-10. Adjusting the presser foot floating amount (minute lifting amount) (option).....	81
12-11. Thread trimming .....	82
<b>13.LIST OF ERROR CODES.....</b>	<b>86</b>
<b>14.TROUBLESHOOTING.....</b>	<b>90</b>

# 1. MACHINE SPECIFICATIONS

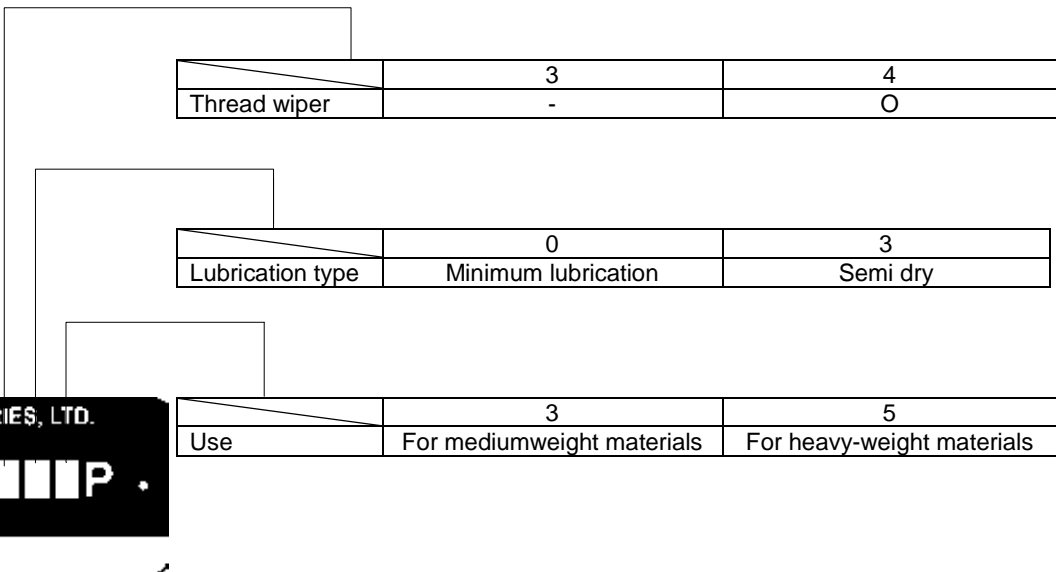

0875D

	-333P, -433P, -303P, -403P	-305P -405P
Max. sewing speed * Standard feed locus	Pitch 4 or less /5000 sti/min More than pitch 4/4000 sti/min	Pitch 4 or less /4500 sti/min More than pitch 4/4000 sti/min
Backtack sewing speed * Standard feed locus	Automatic 150 (*1) - 3000 sti/min, Manual 150 (*1) - 4000 sti/min* (*1) Inching setting speed	
Max. stitch length	5mm	7mm(* 5 mm at time of shipment)
Presser foot height	Lifting lever	6mm
	Knee lifter	16mm
Feed dog height	0.8mm	1.2mm
Needle (DBx1, DPx5)	#11 - #18	#19 - #22
Motor	AC servo motor	
Control circuit	Microprocessor	
Rotary hook	New lubrication-type rotary hook	

Lubricating oil

	-[0]P	-[3]P
Rotary hook	High-speed spindle	High-speed spindle
Needle bar		Special Brother grease

## 2. NAMES OF MAJOR PARTS

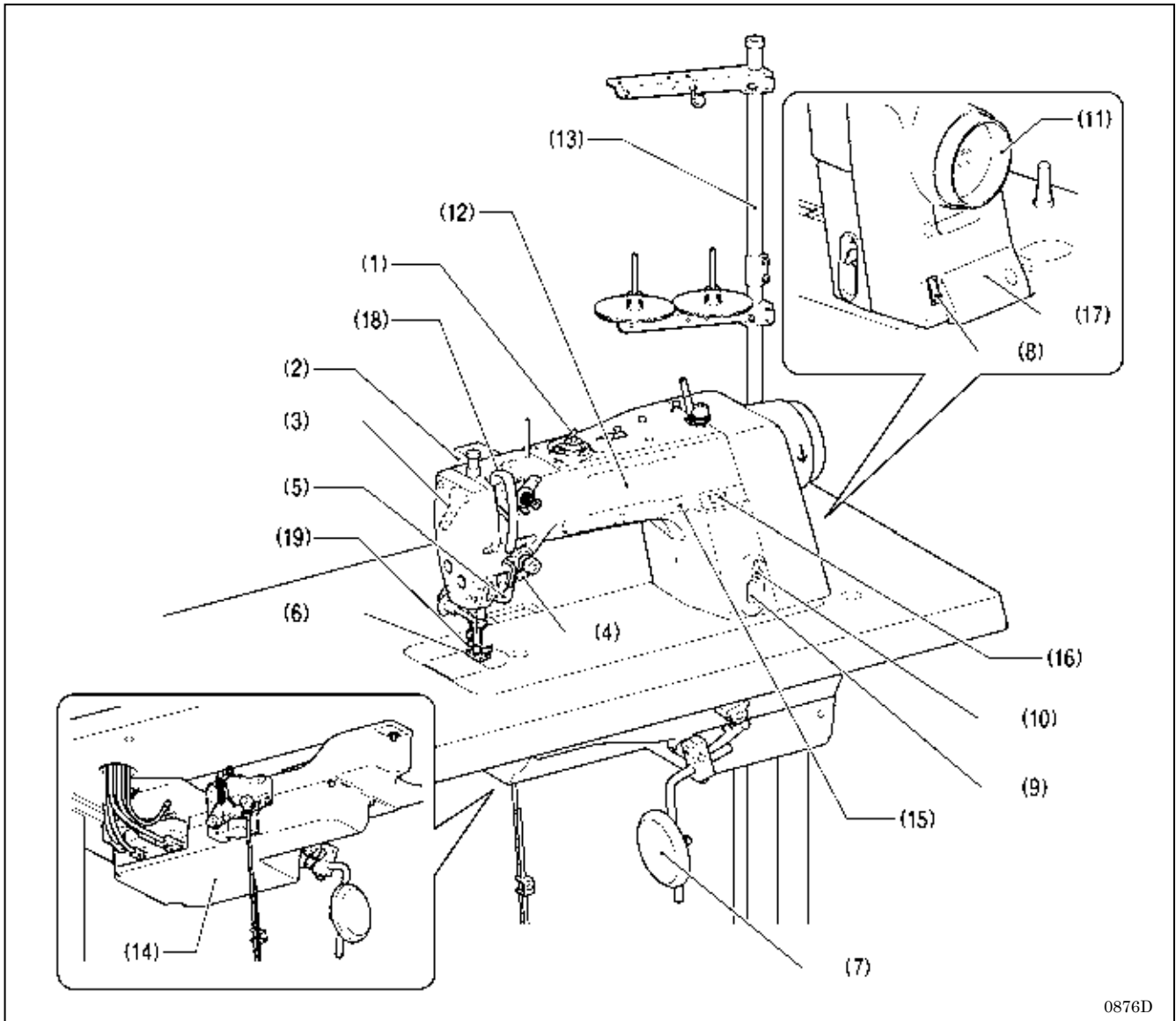

0876D





- |                       |                         |
|-----------------------|-------------------------|
| (1) Bobbin winder     | (2) Thread wiper device |
| (3) Lifting lever     | (4) Hand switch A       |
| (5) Hand switch B     | (6) Work clamp          |
| (7) Knee lifter plate | (8) Power switch        |
| (9) Oil gauge window  | (10) Oil feeding pocket |
| (11) Machine pulley   | (12) Operation panel    |
| (13) Cotton stand     | (14) Control box        |
| (15) Power indicator  | (16) USB port           |



### Safety devices:

- |                   |                           |
|-------------------|---------------------------|
| (17) Pulley cover | (18) Thread take-up cover |
| (19) Finger guard |                           |

# 3. INSTALLATION

## ⚠ CAUTION

-  Machine installation should only be carried out by a qualified technician.
-  Contact your Brother dealer or a qualified electrician for any electrical work that may need to be done.
-  The sewing machine weighs approximately 34.5 kg (76lb). The installation should be carried out by two or more people.
-  Do not connect the power cord until installation is complete. The machine may operate if the treadle is depressed by mistake, which could result in injury.

-  Secure the table so that it will not move when tilting back the machine head. If the table moves, it may crush your feet or cause other injuries.
-  Use both hands to hold the machine head when tilting it back or returning it to its original position. If only one hand is used, the weight of the machine head may cause your hand to slip, and your hand may get caught.

### About the machine set-up location

- Do not set up this sewing machine near other equipment such as televisions, radios or cordless telephones, otherwise such equipment may be affected by electronic interference from the sewing machine.
- The sewing machine should be plugged directly into an AC wall outlet. Operation problems may result if extension cords are used.

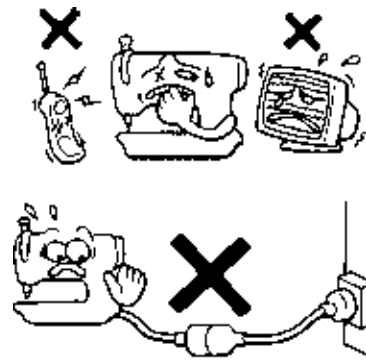

0475D

### Carrying the machine

- The sewing machine should be carried by the arm and the pulley cover by two people as shown in the illustration.
- \* Do not hold by any part other than the pulley cover. If this is not observed, it may result in damage to the sewing machine.
- \* Do not hold the operation panel.

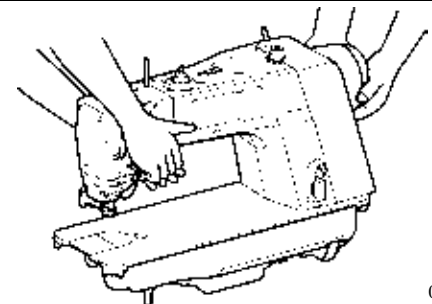

0877D

### Tilting back the machine head

- Hold section (A) with your foot so that the table does not move, and then push the arm with both hands to tilt back the machine head.
- \* Do not push the operation panel.

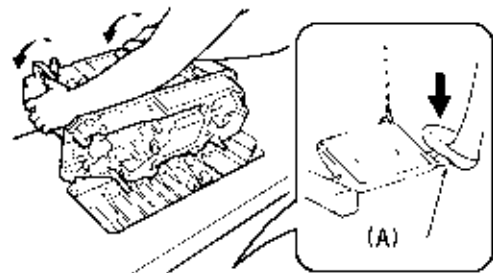

0878D

### Returning the machine head to the upright position

1. Clear away any tools, etc. which may be near the table holes.
  2. While holding the face plate with your left hand, gently return the machine head to the upright position with your right hand.
- \* Do not hold the operation panel.



0879D

### 3-1. Table processing diagram

- The top of the table should be 40 mm in thickness and should be strong enough to hold the weight and with-stand the vibration of the sewing machine.
- Drill holes as indicated in the illustration below.

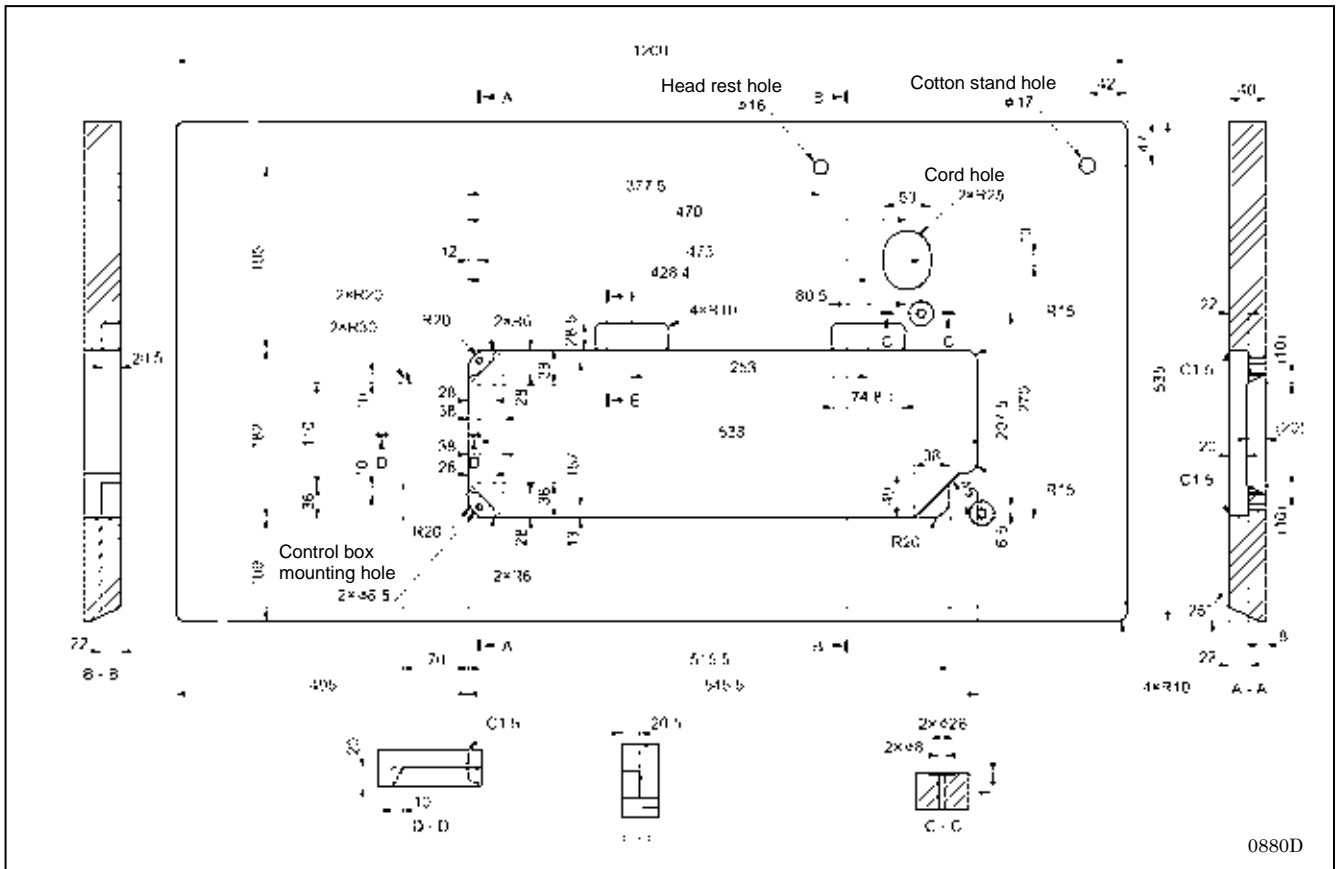

### 3-2. Installation

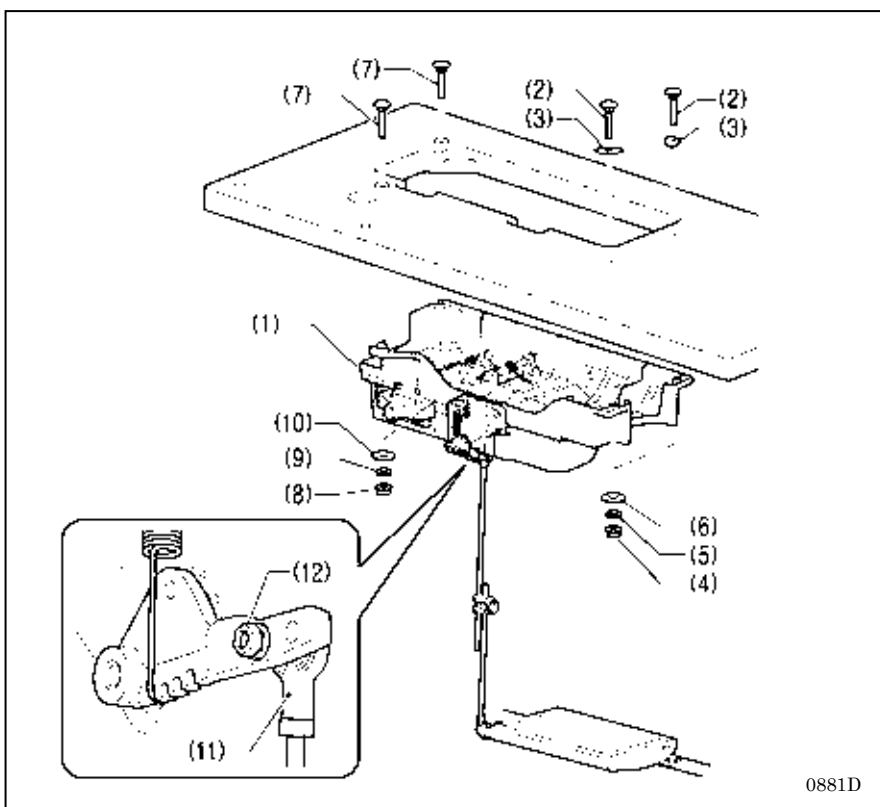

#### 1. Control box

- (1) Control box
- (2) Bolts [4 pcs]
- (3) Washers [2 pcs]
- (4) Nuts [2 pcs]
- (5) Spring washers [2 pcs]
- (6) Washers [2 pcs]
- (7) Bolts (large) [2 pcs]
- (8) Nuts (large) [2 pcs]
- (9) Spring washers (large) [2 pcs]
- (10) Washers (large) [2 pcs]

#### 2. Connecting rod

- (11) Connecting rod
- (12) Nut

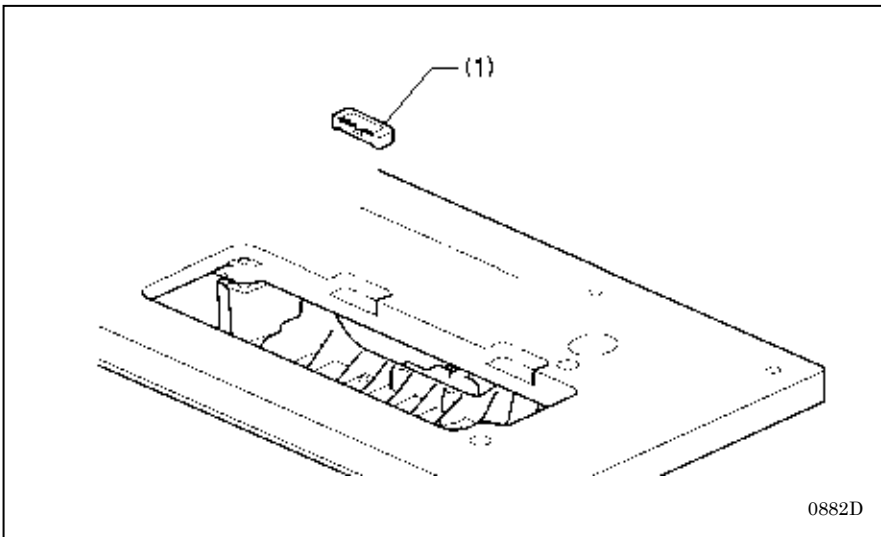

### 3. Rubber cushions

- (1) Rubber cushions [2 pcs]

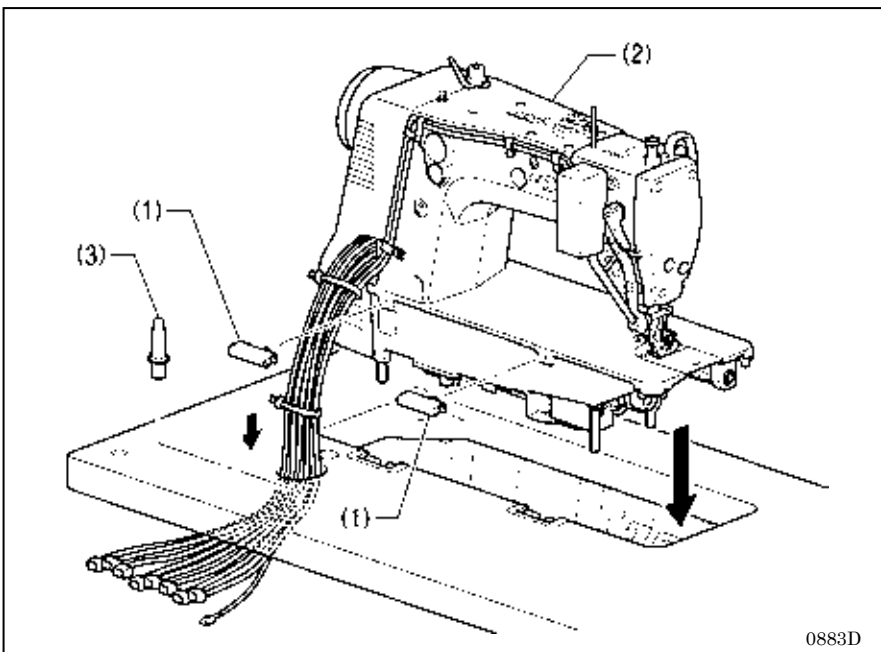

### 4. Machine head

- (1) Hinges [2 pcs]  
 (2) Machine head  
 (3) Head rest

**NOTE:**

- Bind the cords together and pass them through the cord hole.
- Tap the head rest (3) securely into the table hole. If the head rest (3) is not pushed in as far as it will go, the machine head will not be sufficiently stable when it is tilted back.

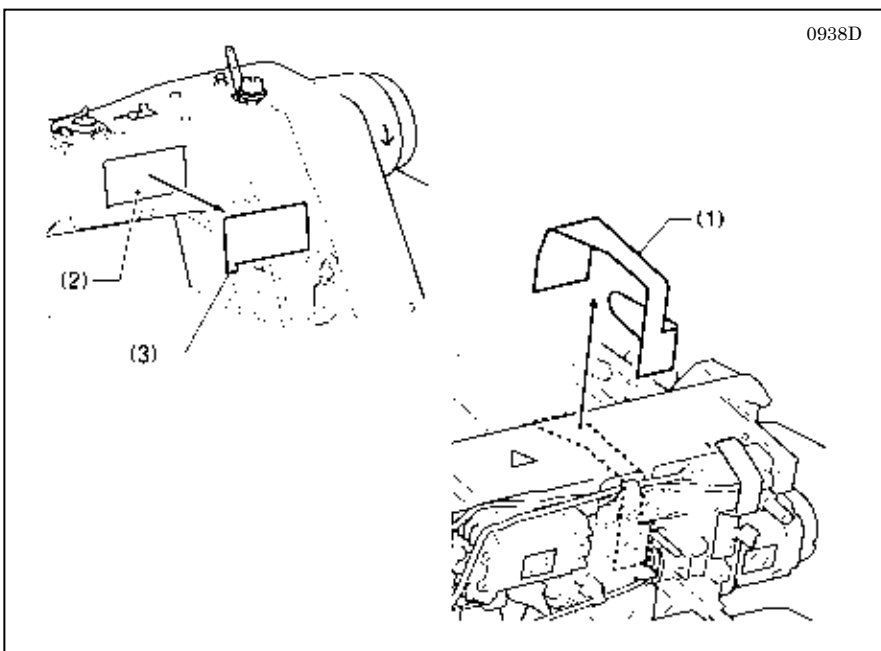

### 5. Machine head seal

1. Tilt back the machine head, and then peel off the sticker (1).
2. Peel off the protective sheet (3) from the operation panel (2).



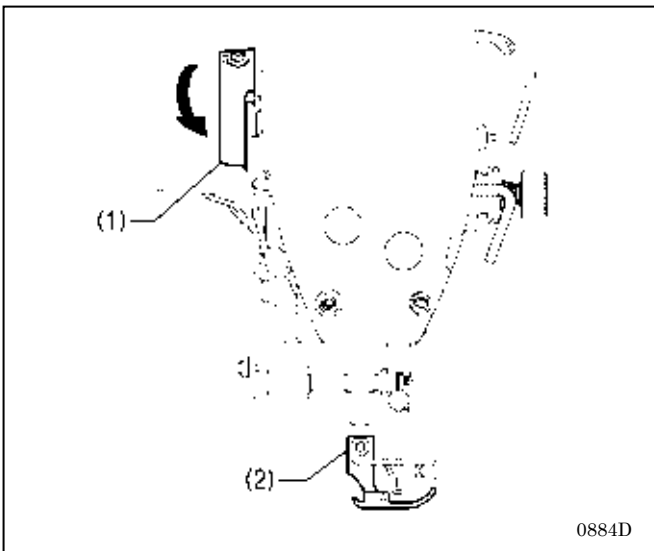

## 6. Knee lifter plate

### <Knee lifter adjustment>

1. Turn the machine pulley so that the feed dog is below the top of the needle plate.
2. Lower the presser foot (1) by using the lifting lever (2).

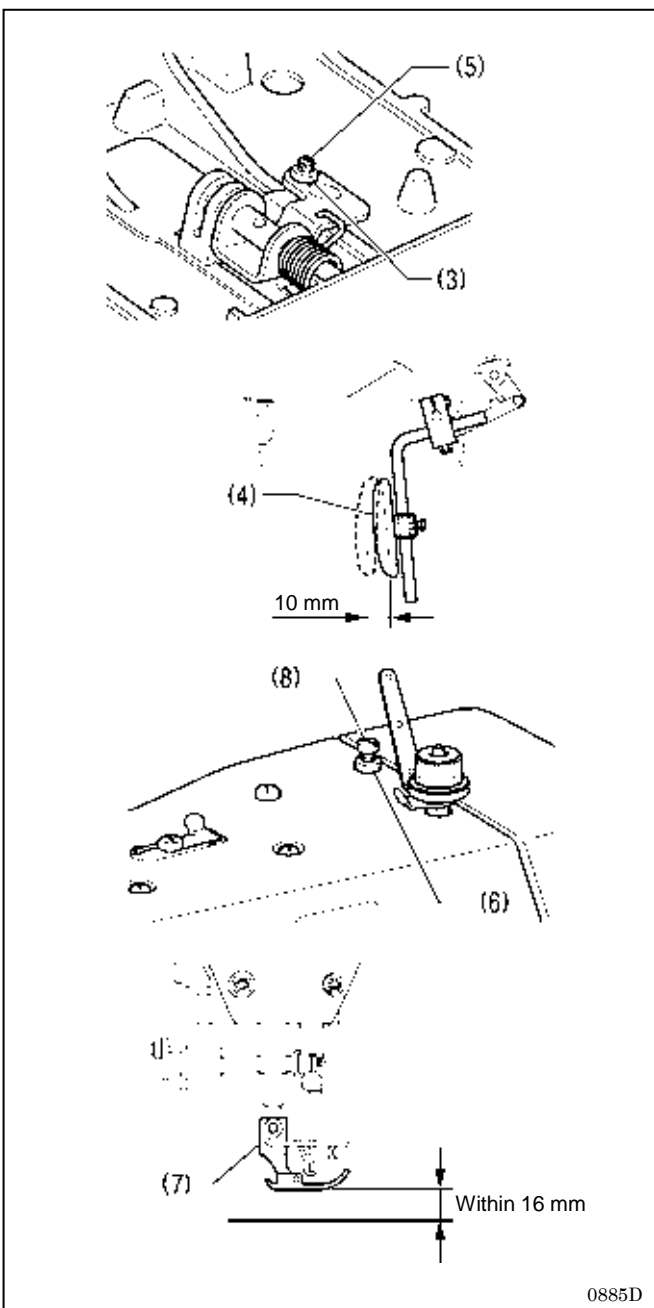



3. Loosen the nut (3).
4. Turn the screw (5) to adjust so that the amount of play in the knee lifter plate (4) is approximately 10 mm.
5. Securely tighten the nut (3).

6. Loosen the nut (6).
7. Turn the adjusting screw (8) to adjust so that the presser foot (7) is at the desired position within a distance of 16 mm of the needle plate when the knee lifter plate is fully pressed.
8. After adjustment is completed, securely tighten the nut (6).

3-3. Lubrication

**CAUTION**

-  Do not connect the power cord until lubrication has been completed, otherwise the machine may operate if the treadle is depressed by mistake, which could result in injury.
-  Be sure to wear protective goggles and gloves when handling the lubricating oil and grease, so that they do not get into your eyes or onto your skin, otherwise inflammation can result. Furthermore, do not drink the oil or eat the grease under any circumstances, as they can cause vomiting and diarrhea. Keep the oil out of the reach of children.
-  When cutting the nozzle of the oil tank, hold the base of the nozzle securely. If you hold the end of the nozzle, injury from the scissors may result.

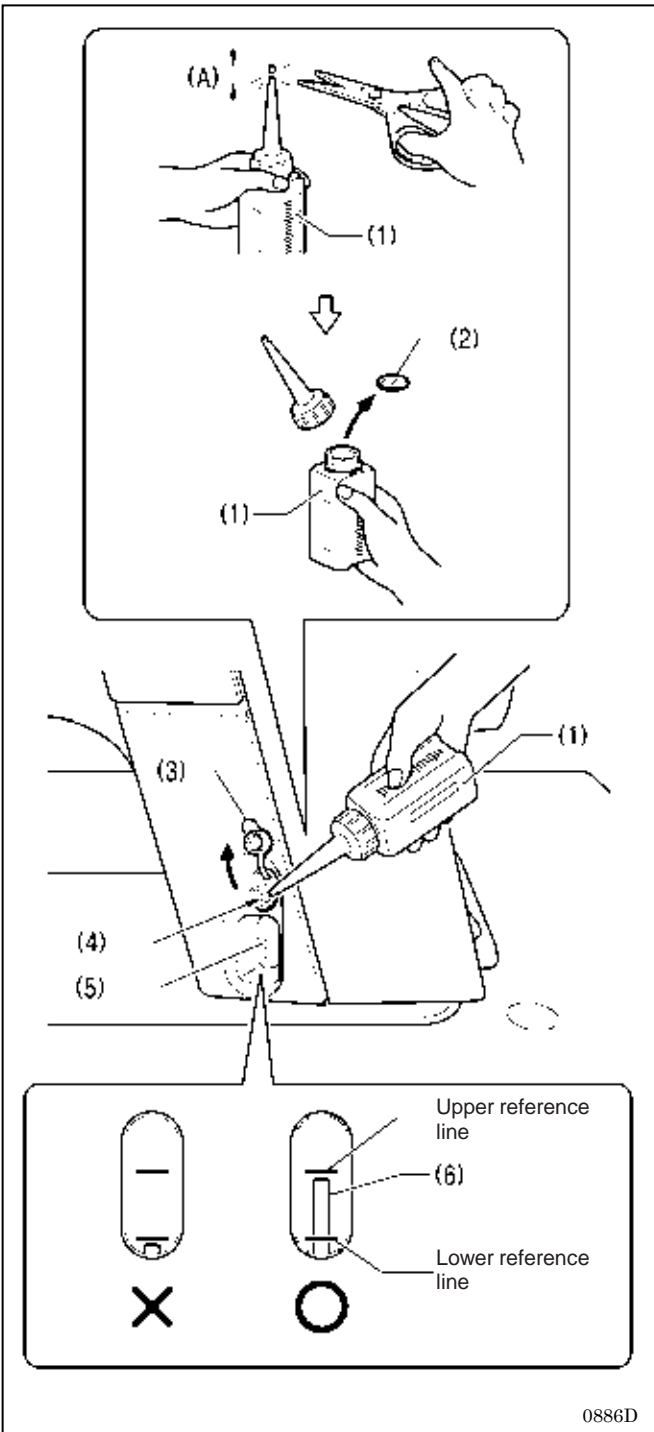

The sewing machine should always be lubricated and the oil supply replenished before it is used for the first time, and also after long periods of non-use.

1. Hold the base of the nozzle of the accessory oil tank (1), and use scissors to cut about half-way along the straight section (A) of the nozzle.
2. Loosen and remove the nozzle, and then remove the seal (2).
3. Tighten the nozzle.
4. Open the oil feeding pocket cover (3).
5. Insert the nozzle of the oil tank (1) deeply into the oil feeding pocket (4), and then add about 120 ml of lubricating oil.
6. Check that the oil gauge (6) comes to the upper reference line in the oil gauge window (5).
7. Close the oil feeding pocket cover (3).

**<Lubrication oil replenishment interval>**

Be sure to add more oil if the oil gauge (6) is below the lower reference line.

0886D

### 3-4. Connecting the cords

#### ! CAUTION



Contact your Brother dealer or a qualified electrician for any electrical work that may need to be done.



Do not connect the power cord until all cords have been connected.

The machine may operate if the treadle is depressed by mistake, which could result in injury.



When securing the cords, do not bend the cords excessively or fasten them too hard with staples, otherwise there is the danger that fire or electric shocks could occur.



Be sure to connect the ground. If the ground connection is not secure, you run a high risk of receiving a serious electric shock, and problems with correct operation may also occur.

#### 3-4-1. Connecting the cords

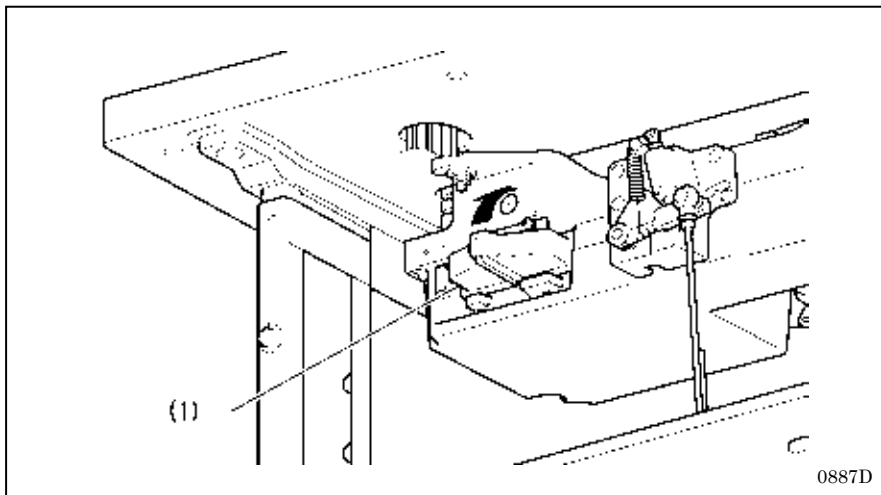

##### 1. Harness cover

1. Raise the harness cover (1).

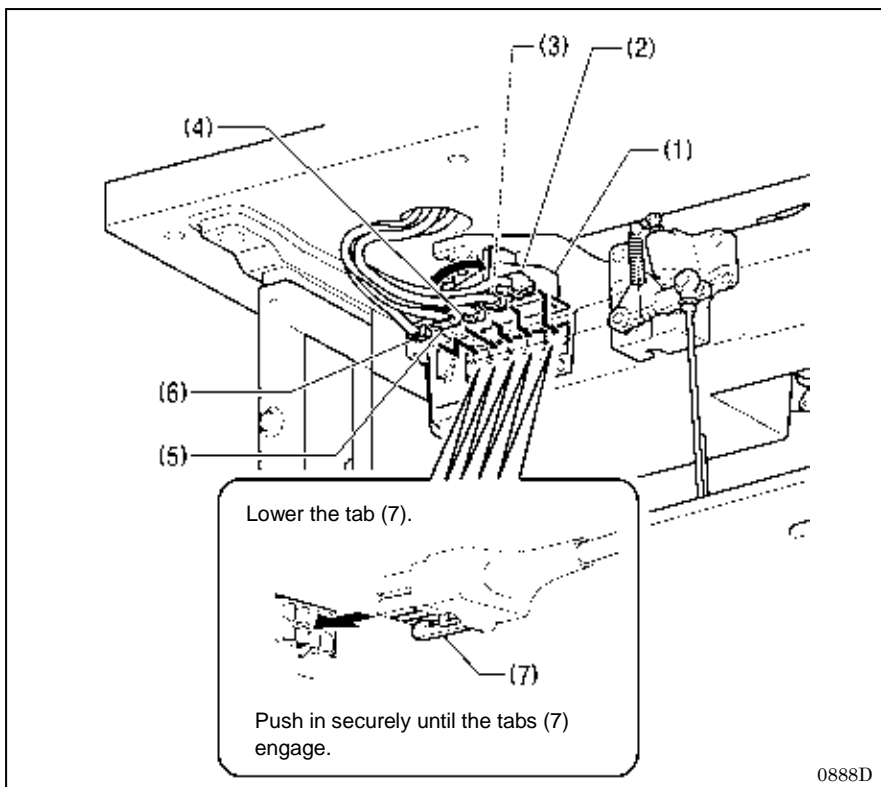

##### 2. Cords (1)

- (1) Harness cover
- (2) Sewing machine motor encoder connector 16-pin
- (3) Feed motor encoder connector 6-pin
- (4) Hand switch connector 12-pin
- (5) 10-pin operation panel connector
- (6) 10-pin solenoid connector

1. Pass the cords through the harness cover (1).
2. Connect the cords to the control box.

##### NOTE:

For Europe specifications, Americas 220V specifications and 100V/400V system specifications, refer to "3-4-2. Other cords".

### 3. INSTALLATION

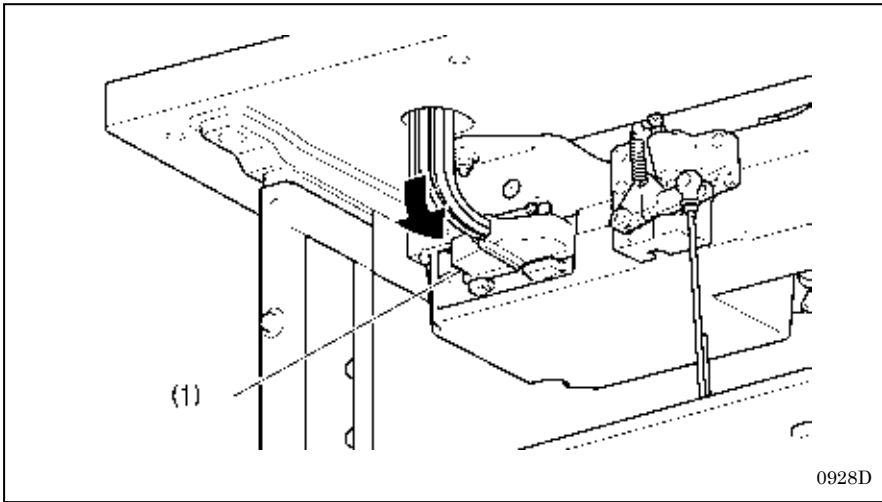

3. Lower the harness cover (1), and then place the harness inside the harness cover.

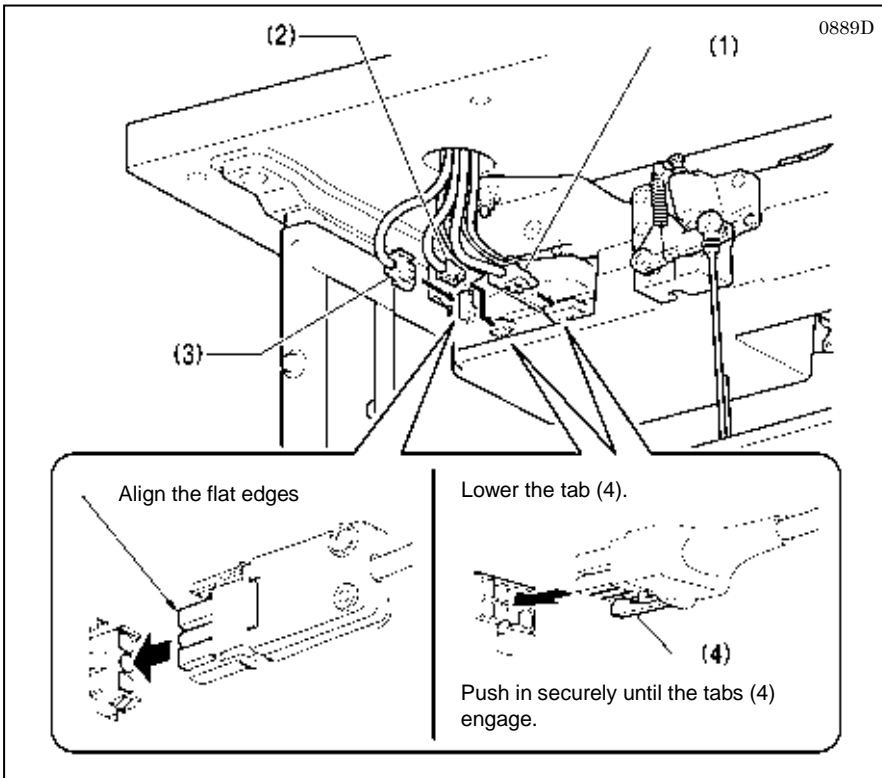

### 3. Cords (2)

- (1) 4-pin machine motor connector
- (2) Feed motor connector 6-pin
- (3) 3-pin power connector

### 4. Ground wire

- (1) Ground wire
- (2) Screw (Recommended tightening torque  $1.0 \pm 0.1$  N.m)
- (3) Power cord

1. Attach an appropriate plug to the power cord (3). (The green and yellow wire is the ground wire.)
2. Insert the power plug into a properly-grounded electrical outlet.

#### NOTE:

- Make sure that the ground connections are secure in order to ensure safety.
- For Europe specifications, Americas 220 V specifications and 100 V/400 V system specifications, refer to "3-4-2. Other cords".

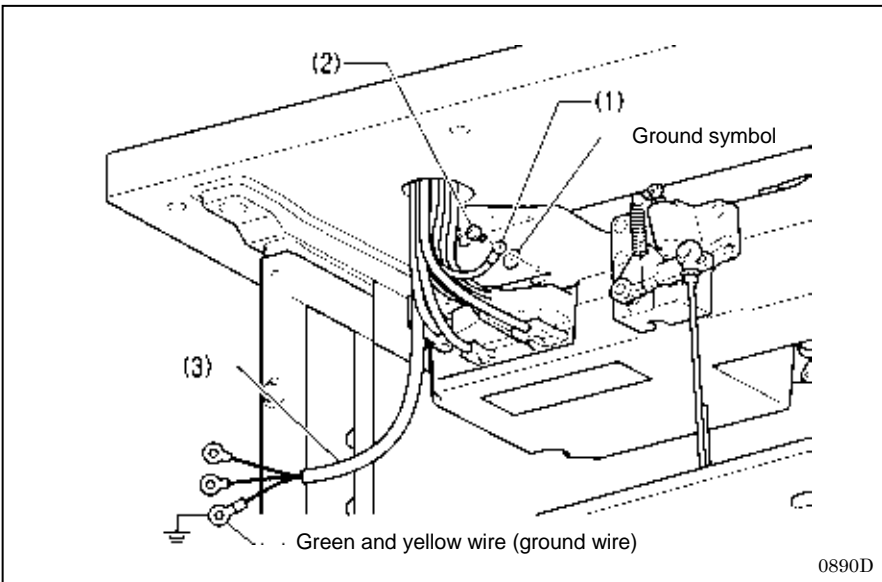

## 3-4-2. Other cords

**! DANGER**

Wait at least 5 minutes after turning off the power switch and disconnecting the power cord from the wall outlet before opening the cover of the control box. Touching areas where high voltages are present can result in severe injury.

For Europe specifications, Americas 220V specifications and 100 V/400 V system specifications, connect the cords according to the respective specifications.

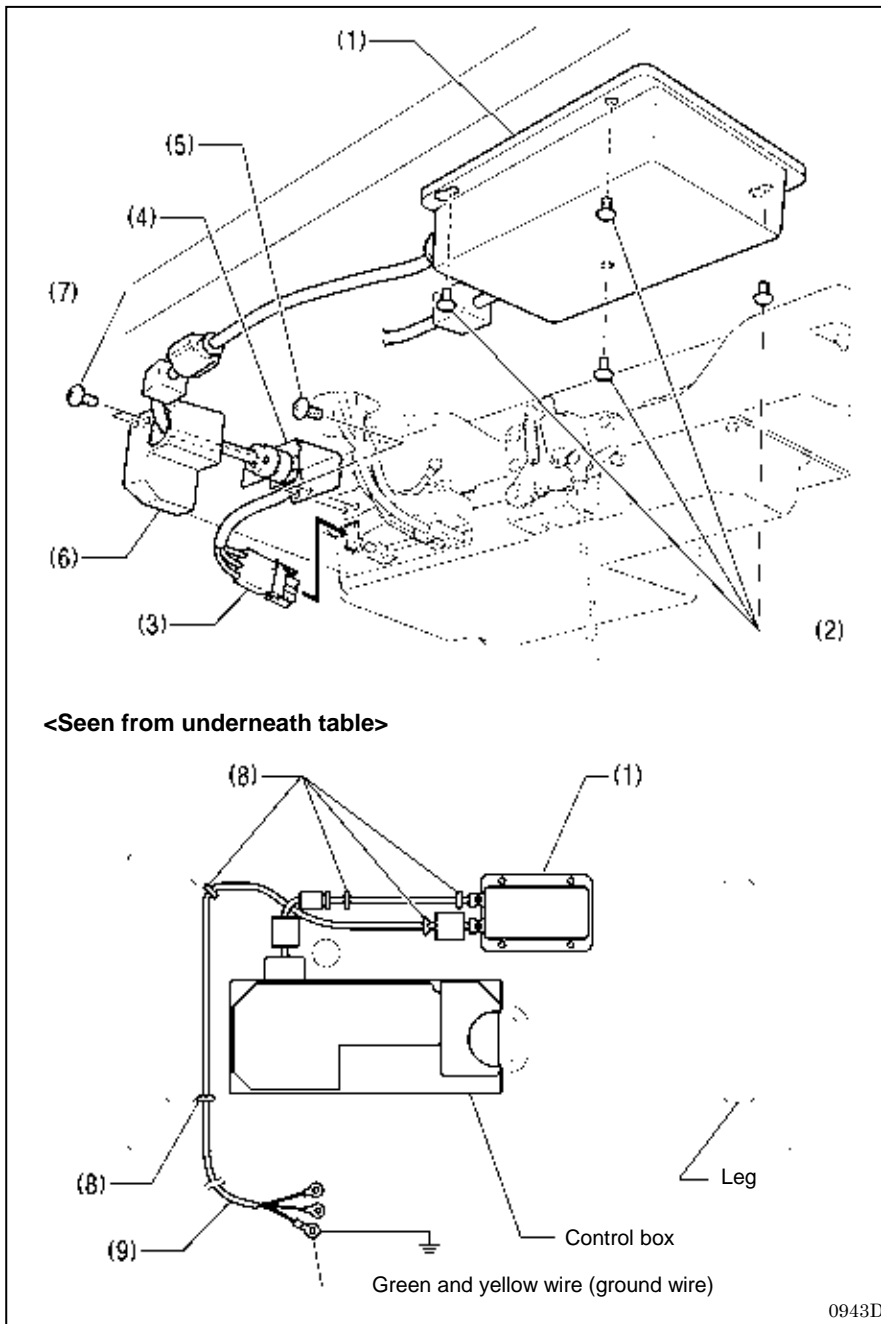
**< Europe specifications >**

- (1) Filter box
- (2) Screws [4 pcs]
- (3) Connector
- (4) CE bush plate
- (5) Screws [2 pcs]
- (6) CE D cord cover
- (7) Screws [2 pcs]
- (8) Staples [5 pcs]
- (9) Power cord

1. Attach an appropriate plug to the power cord (9). (The green and yellow wire is the ground wire.)
2. Insert the power plug into a properly-grounded electrical outlet.

**NOTE:**

- Take care when tapping in the staples (8) to make sure that they do not pierce the cords.
- Do not use extension cords, otherwise machine operation problems may result.

0943D

### 3. INSTALLATION

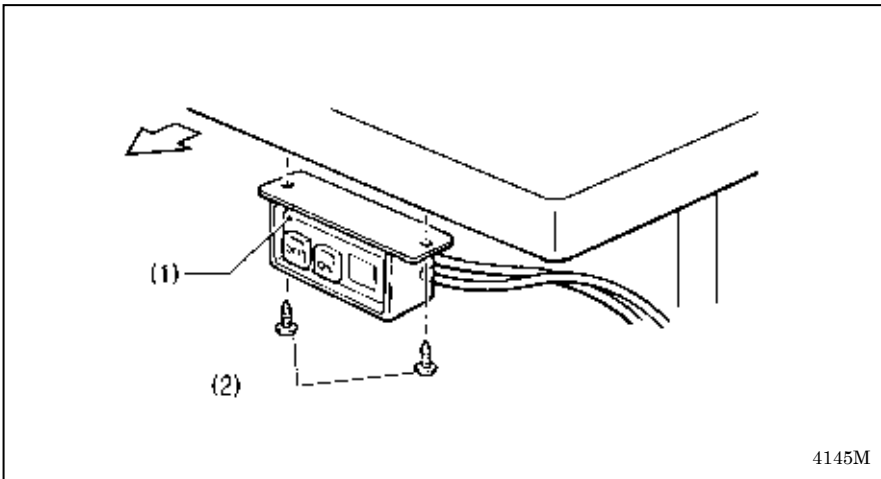

<For 100V/400V system specifications>

- (1) Power switch
- (2) Screws [2 pcs]

4145M

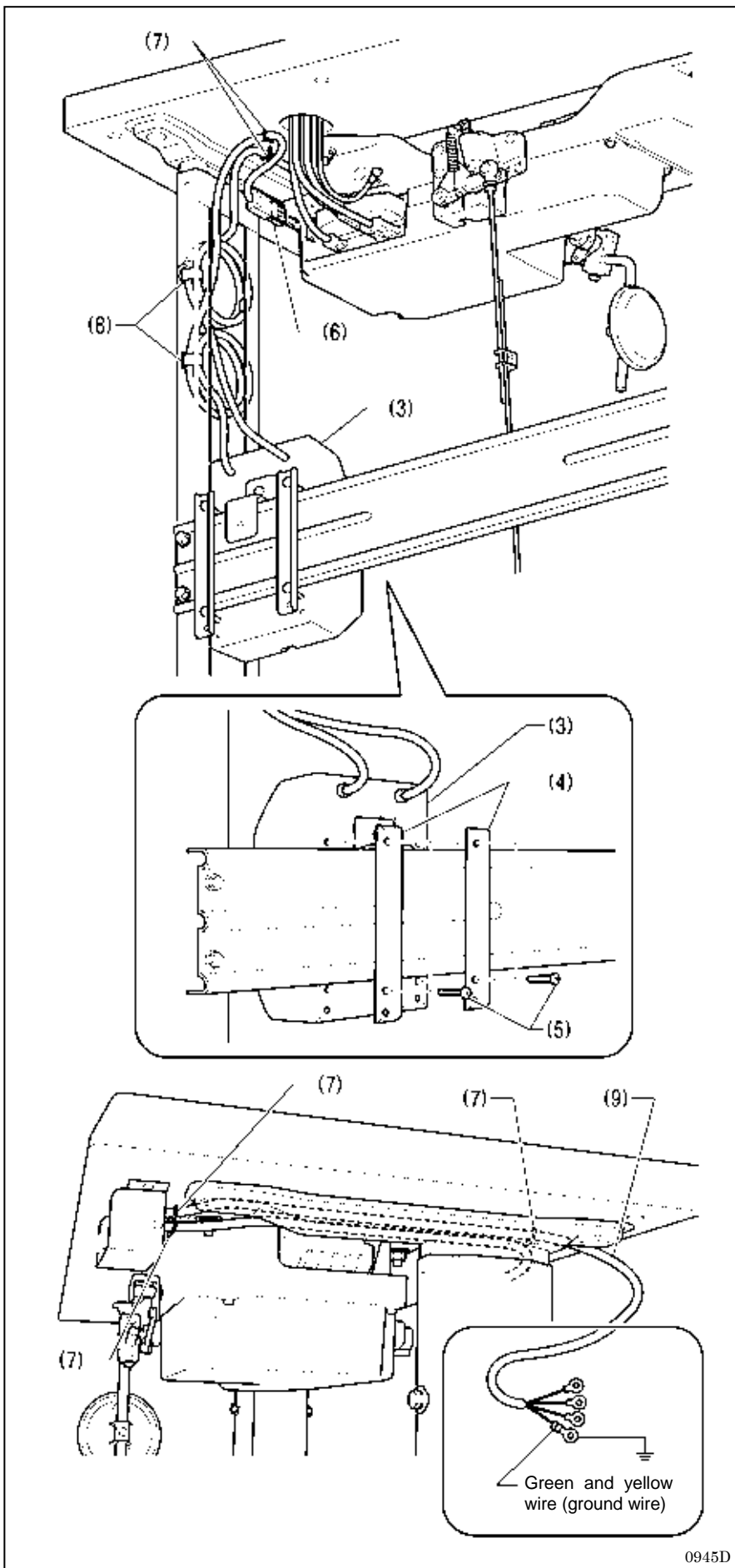

- (3) Transformer box
- (4) Transformer box plates [2 pcs]
- (5) Screw [with washer]
- (6) 3-pin power supply connector
- (7) Staples [5 pcs]
- (8) Cord clamps [2 pcs]
- (9) Power cord

1. Attach an appropriate plug to the power cord (9). (The green and yellow wire is the ground wire.)
2. Insert the power plug into a properly-grounded electrical outlet.

**NOTE:**

- Take care when tapping in the staples (7) to make sure that they do not pierce the cords.
- Do not use extension cords, otherwise machine operation problems may result.

0945D

### 3. INSTALLATION

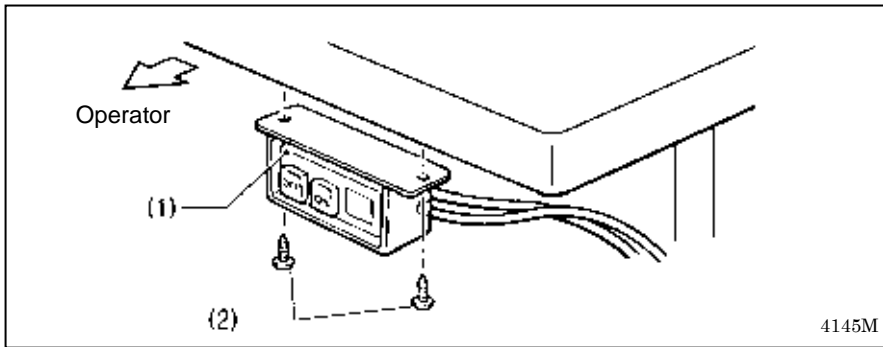

<For Americas 220V specifications>

- (1) Power switch
- (2) Screws [2 pcs]

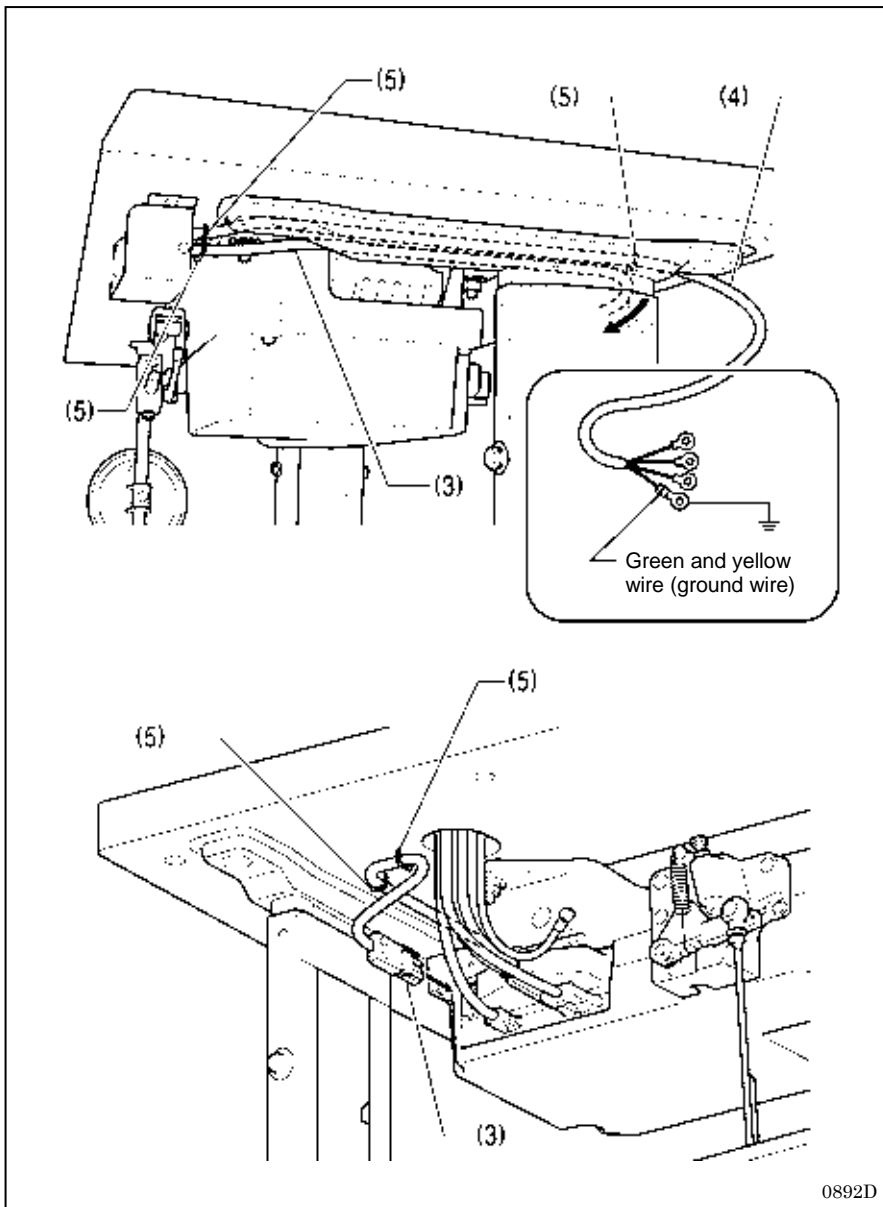

- (3) 3-pin power supply connector
- (4) Power cord
- (5) Staples [5 pcs]

1. Attach an appropriate plug to the power cord (4). (The green and yellow wire is the ground wire.)
2. Insert the power plug into a properly-grounded electrical outlet.

**NOTE:**

- Take care when tapping in the staples (5) to make sure that they do not pierce the cords.
- Do not use extension cords, otherwise machine operation problems may result.



### 3-5. Test operation (Operating the treadle)

## ⚠ CAUTION



Do not touch any of the moving parts or press any objects against the machine while sewing, as this may result in personal injury or damage to the machine.

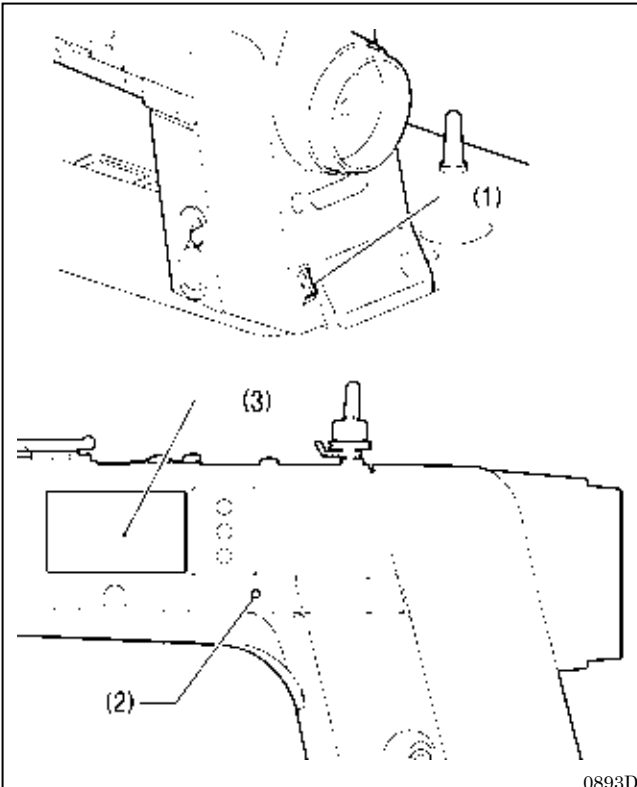

0893D

#### 1. Turning on the power

Press the ON power switch (1).

The power indicator (2) will illuminate.

The display (3) of the operation panel will change in the order shown in the illustration. (During this time, the feed mechanism will return to the home position.)

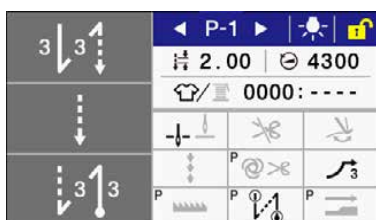
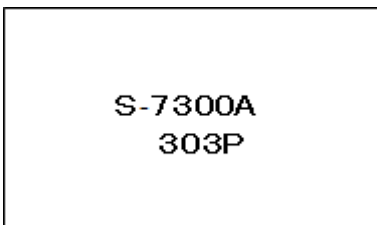

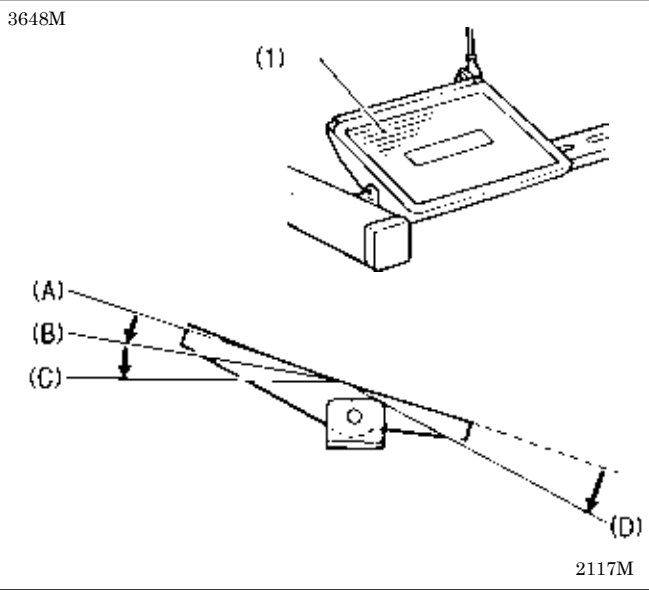

## 2. Test operation

1. Check that the machine sews at low speed when the treadle (1) is gently pressed to position (B).
2. Then check that it sews at high speed when the treadle (1) is gently pressed to position (C).
3. After pressing the treadle (1) forward, check that the needle is lowered to the top of the needle plate when the treadle (1) is returned to the neutral position (A). (when needle down stopping has been set.)
4. If the treadle (1) is pressed to position (D), thread trimming is carried out and the needle then rises above the needle plate and stops.

## 3-6. Adjusting the treadle

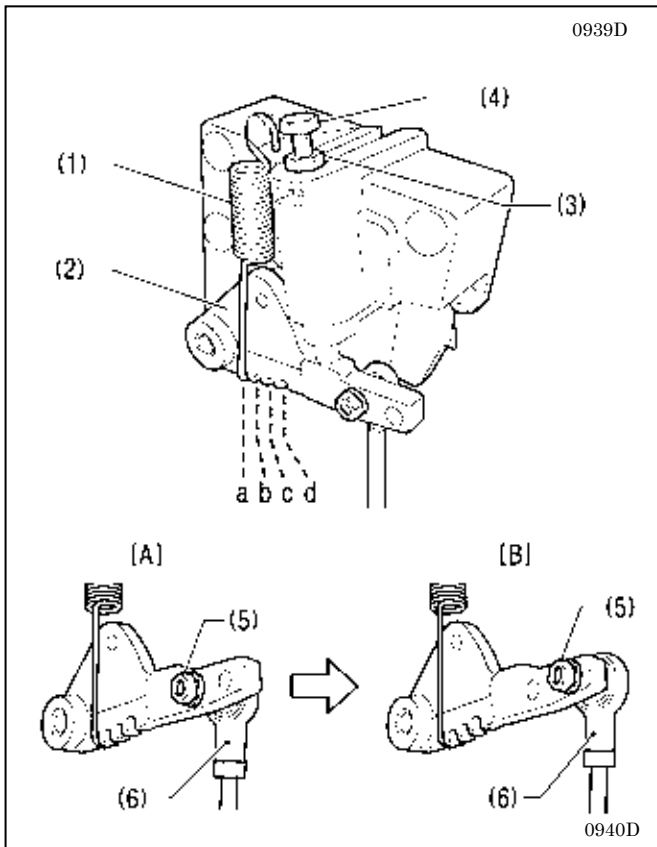

### <Forward depression sensitivity adjustment>

If the machine starts running at low speed when your foot is simply resting on the treadle, or if the treadle pressure is felt to be too weak, adjust the position (a to c) at which the treadle spring (1) is hooked onto the treadle lever (2).

\* a is the weakest position, and it becomes gradually stronger at b, c and d respectively.

### <Backward depression sensitivity adjustment>

1. Loosen the nut (3) and turn the bolt (4).

\* When the bolt (4) is tightened, the treadle operation becomes heavier, and when it is loosened, the operation becomes lighter.

2. Tighten the nut (3).

### < Adjusting the treadle stroke >

Remove the nut (5), and then move the connecting rod joint (6) from the position in figure A to the position in figure B. The treadle stroke will then be increased by approximately 27 %.

At this time, the treadle forward and backward depression sensitivity will change, so readjust if necessary.

## 4. PREPARATION BEFORE SEWING

### 4-1. Installing the needle

#### ⚠ CAUTION



Turn off the power switch before installing the needle.  
The machine may operate if the treadle is depressed by mistake, which could result in injury.

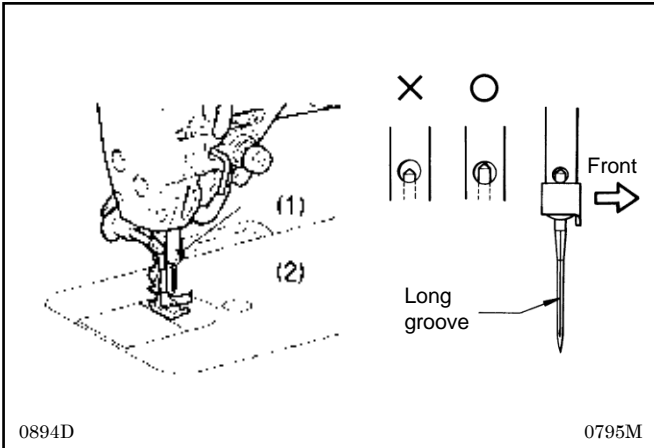

1. Turn the machine pulley to move the needle bar to its highest position.
2. Loosen the screw (1).
3. Insert the needle (2) in a straight line as far as it will go, making sure that the long groove on the needle is at the left, and then securely tighten the screw (1).

### 4-2. Removing the bobbin case

#### ⚠ CAUTION



Turn off the power switch before removing the bobbin case.  
The machine may operate if the treadle is depressed by mistake, which could result in injury.

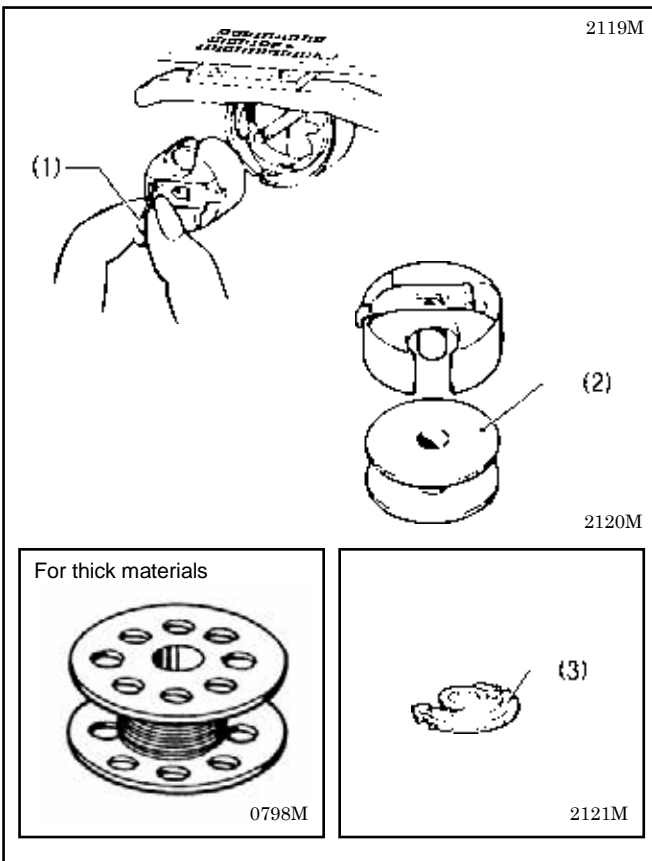

1. Turn the machine pulley to raise the needle until it is above the needle plate.
2. Pull the latch (1) of the bobbin case upward and then remove the bobbin case.
3. The bobbin (2) will come out when the latch (1) is released.

- \* There is an anti-spin spring (3) inside the bobbin case. The anti-spin spring (3) prevents the bobbin from racing at times such as during thread trimming.
- \* Use bobbins (2) made of light alloy as specified by BROTHER.

## 4. PREPARATION BEFORE SEWING

### 4-3. Winding the lower thread

#### ⚠ CAUTION



Do not touch any of the moving parts or press any objects against the machine while winding the lower thread, as this may result in personal injury or damage to the machine.

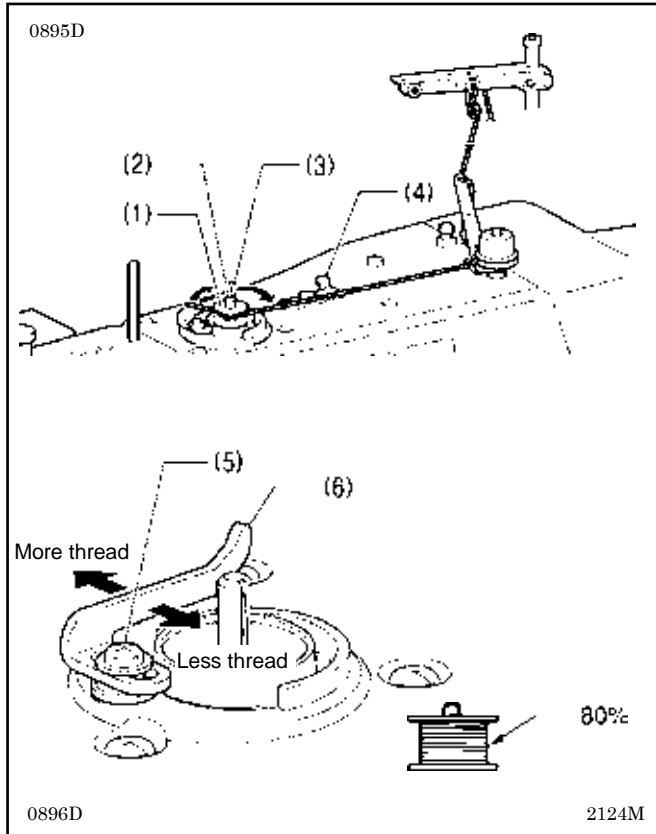

1. Turn on the power switch.
2. Place the bobbin (1) onto the bobbin winder shaft (2).
3. Wind the thread several times around the bobbin (1) in the direction indicated by the arrow.
4. Push the bobbin presser arm (3) toward the bobbin(1).
5. Raise the presser foot with the lifting lever.
6. Depress the treadle. Lower thread winding will then start.
7. Once winding of the lower thread is completed, the bobbin presser arm (3) will return automatically.
8. After the thread has been wound on, remove the bobbin and cut the thread with the knife (4).

- \* Loosen the screw (5) and move the bobbin presser (6) to adjust the amount of thread wound onto the bobbin.

#### NOTE:

The amount of thread wound onto the bobbin should be a maximum of 80 % of the bobbin capacity.

### 4-4. Installing the bobbin case

#### ⚠ CAUTION



Turn off the power switch before installing the bobbin case.  
The machine may operate if the treadle is depressed by mistake, which could result in injury.

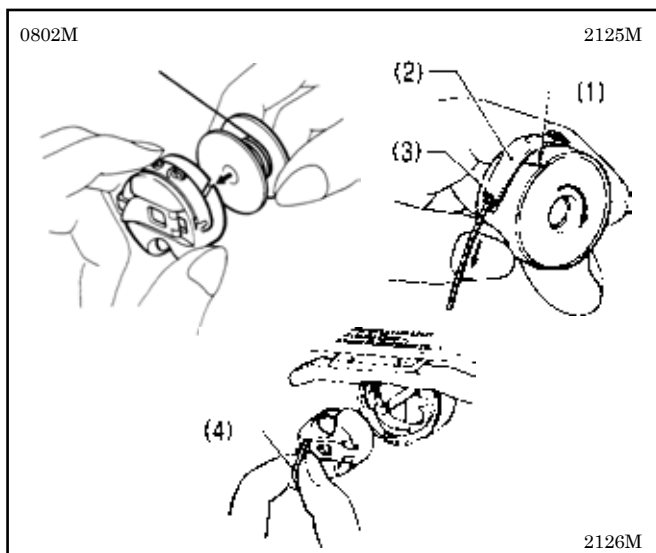

1. Turn the machine pulley to raise the needle until it is above the needle plate.
2. While holding the bobbin so that the thread winds to the right, insert the bobbin into the bobbin case.
3. Pass the thread through the slot (1) and under the tension spring (2), and then pull it out from the thread guide (3).
4. Check that the bobbin turns clockwise when the thread is pulled.
5. Hold the latch (4) on the bobbin case and insert the bobbin case into the rotary hook.

## 4-5. Threading the upper thread

**CAUTION**

Turn off the power switch before threading the upper thread.  
The machine may operate if the treadle is depressed by mistake, which could result in injury.

Turn the machine pulley and raise the thread take-up (1) before threading the upper thread.  
This will make threading easier and it will prevent the thread from coming out at the sewing start.

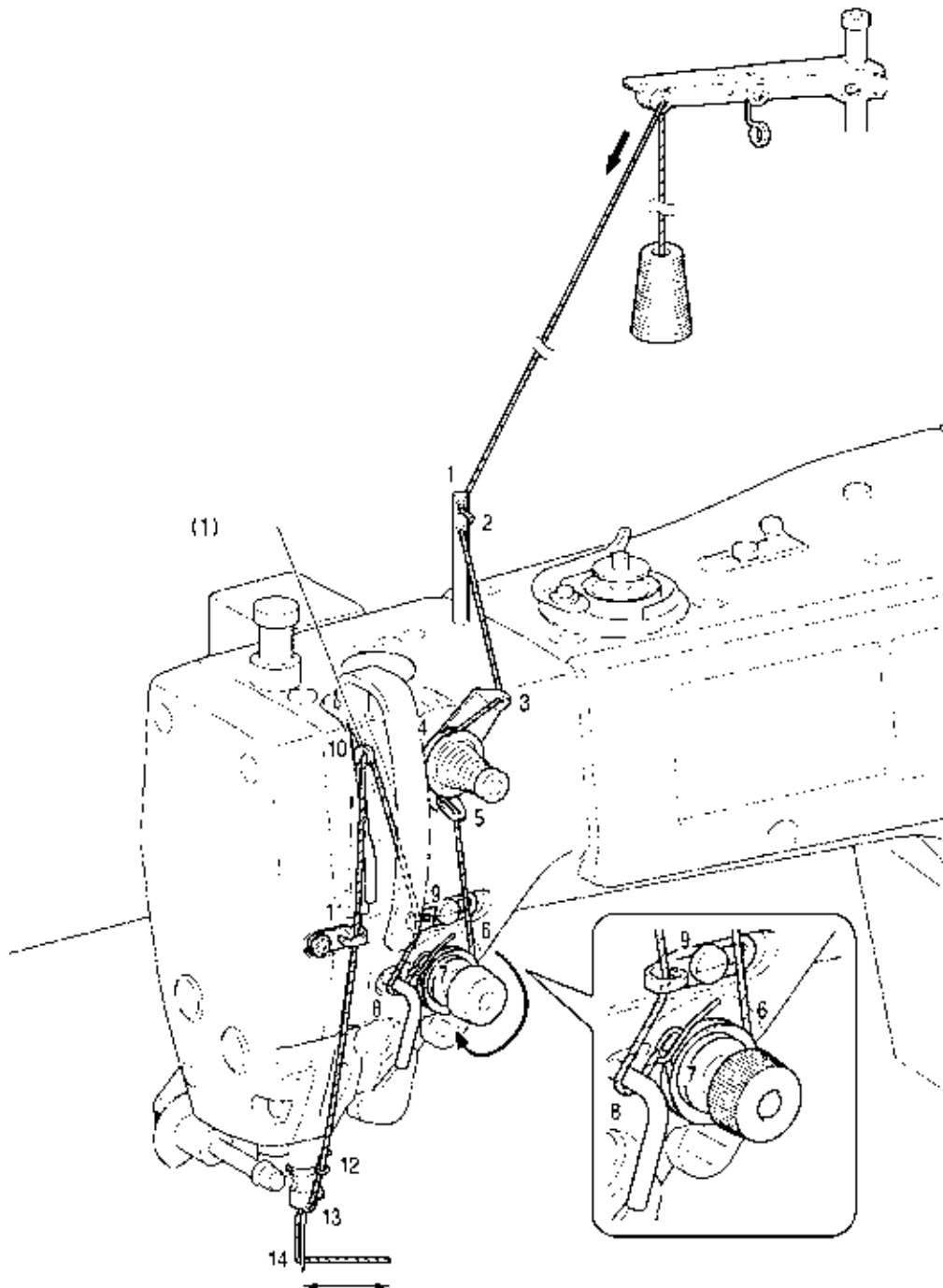

0897D

### 4-6. Using the knee lifter

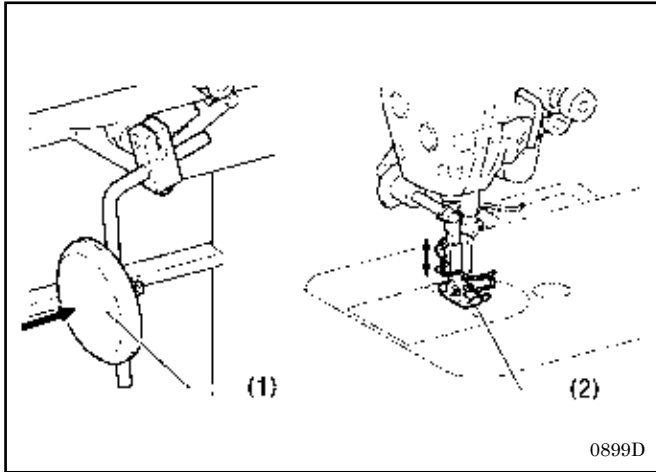

The presser foot (2) can be raised by pressing the knee lifter plate (1).

## 5. USING THE OPERATION PANEL (BASIC OPERATIONS)

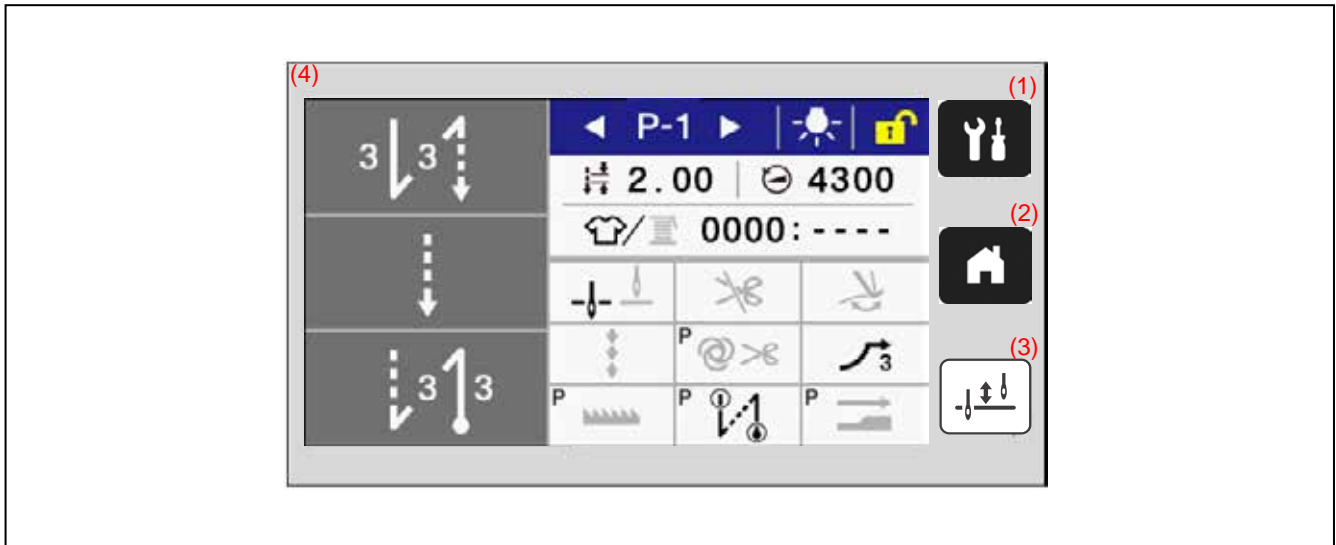

### 5-1. Names and functions



- (1) Menu key  
This key is used to move to the menu screen.
- (2) Home key  
This key is used to return to the home screen.
- (3) Half stitch key  
When the sewing machine is stopped, the needle bar can be moved up and down by pressing this key.
- (4) Touch panel (display)  
This displays messages and touch keys (icons).



### 5-2. Home screen

- The home screen is displayed when the power is turned on.
- Sewing operations are normally carried out while the home screen is displayed.
- The home screen can be switched between the detailed home screen and the simple home screen.  
\*At the time of shipment from the factory, the detailed home screen is set to be displayed.
- If you keep pressing the  key while the home screen is displayed, you can switch between the detailed home screen and the simple home screen.  
Furthermore, you can return to the home screen from any other screen by pressing the  key.

Detailed home screen

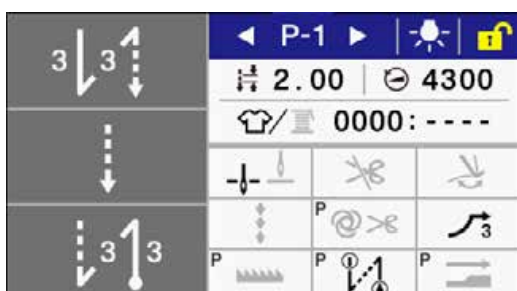

Simple home screen



5-2-1. Description of detailed home screen

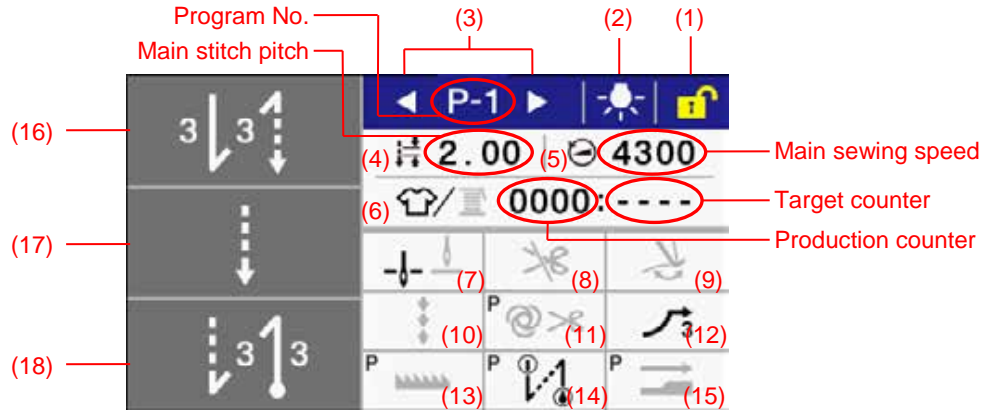

(1)	Screen lock key	Press this key to switch the home screen between locked and unlocked. <b>NOTE:</b> At the time of shipment from the factory, the screen is set to lock automatically if no operations are carried out for one minute. (Refer to memory switch MSW-310.)
	Screen unlock key	
(2)	Illumination LED on key	Press this key to switch the illumination LED between on and off. If you keep pressing this key, the display switches to the illumination LED brightness setting screen.
	Illumination LED off key	
(3)	Program No. UP key	Press this key to increase the program number.
	Program No. DOWN key	Press this key to decrease the program number.
(4)	Main stitch pitch key	If you keep pressing this key, the display switches to the stitch pitch setting screen.
(5)	Main sewing speed key	If you keep pressing this key, the display switches to the main sewing speed setting screen.
(6)	Production counter key	If you keep pressing this key while the production counter is displayed, the display switches to the production counter setting screen.
	Lower thread counter key	If you keep pressing this key while the production counter is displayed, the display switches to the production counter setting screen.
(7)	Needle up/down key	Press this key to switch the stop position after sewing (needle up/needle down).
(8)	Thread trimming lock key	Press this key to switch thread trimming locking (disabled/enabled) when the treadle is depressed backward.
(9)	Thread wiper key	Press this key to switch the thread wiper operation (off/on).
(10)	Correction key	Press this key to switch correction sewing operation (off/on) by using the hand switch.
(11)	AUTO key	Press this key to switch between different sewing operations (normal sewing /automatic sewing/automatic sewing with thread trimming).
(12)	Slow start key	Press this key to switch slow start operation at the sewing start (off/1/2/3/4).
(13)	Special locus key	Press this key to switch the special locus operation for the feed dog (off/1/2/3).
(14)	Best PFM key	Press this key to switch the best PFM mode (off/pulling out/short trailing length/pulling out + short trailing length). If you keep pressing this key, the display switches to the best PFM mode setting screen.
(15)	X-over seam assist mode key	This switches X-over seam assist mode (disabled/enabled). If you keep pressing this key, the display switches to the X-over seam assist mode setting screen.
(16)	Start backtack key	Press this key to switch the start backtack sewing operation (off/on). If you keep pressing this key, the display switches to the start backtack setting screen.
(17)	Main sewing key	If you keep pressing this key, the display switches to the main sewing setting screen.
(18)	End backtack key	Press this key to switch the end backtack sewing operation (off/on). If you keep pressing this key, the display switches to the end backtack setting screen.



5-2-2. Description of simple home screen

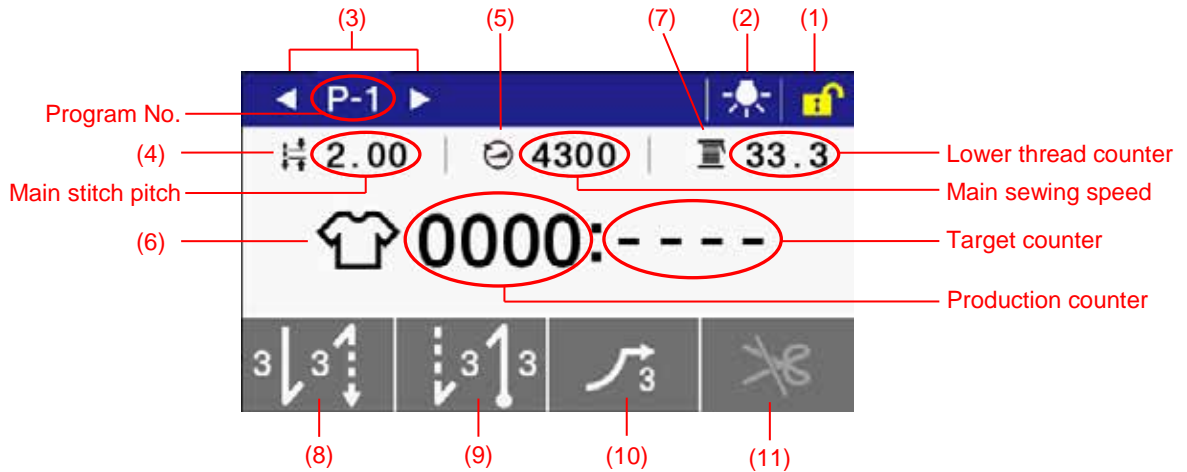

(1)	Screen lock key	Press this key to switch the home screen between locked and unlocked.
	Screen unlock key	<b>NOTE:</b> At the time of shipment from the factory, the screen is set to lock automatically if no operations are carried out for one minute. (Refer to memory switch MSW-310.)
(2)	Illumination LED on key	Press this key to switch the illumination LED between on and off.
	Illumination LED off key	If you keep pressing this key, the display switches to the illumination LED brightness setting screen.
(3)	Program No. UP key	Press this key to increase the program number.
	Program No. DOWN key	Press this key to decrease the program number.
(4)	Main stitch pitch key	If you keep pressing this key, the display switches to the stitch pitch setting screen.
(5)	Main sewing speed key	If you keep pressing this key, the display switches to the main sewing speed setting screen.
(6)	Production counter key	If you keep pressing this key while the production counter is displayed, the display switches to the production counter setting screen.
(7)	Lower thread counter key	If you keep pressing this key while the production counter is displayed, the display switches to the production counter setting screen.
(8)	Shortcut 1 key	This key is set to operate as a "Start backtack key" at the time of shipment from the factory.
(9)	Shortcut 2 key	This key is set to operate as an "End backtack key" at the time of shipment from the factory.
(10)	Shortcut 3 key	This key is set to operate as a "Slow start key" at the time of shipment from the factory.
(11)	Shortcut 4 key	This key is set to operate as a "Thread trimming lock key" at the time of shipment from the factory.



\* The assignments for shortcut keys 1 to 4 can be changed.  
(Refer to "6-5. Assigning functions to shortcut keys".)

### 5-2-3. Types of icons

The icons which appear in the display can be broadly classified into the following three types.



Type A: Simple symbols

<Example>

Warning symbol 	USB connector 	Current program No. 
---	--	--













Type B: Plain touch keys (symbol is always fixed)

<Example>



Return key (Returns to the previous screen) 	+ key (Increases a value) 	OK key (Confirms a value) 
---	--	---

Type C: Touch keys which change their setting status (symbol) each time they are touched

<Example>

	Unlocked 	Locked 
Lock key	 	
	Thread wiping enabled 	Thread wiping disabled 
Thread wiper key	 	
	Start backtack enabled 	Start backtack disabled 
Start backtack key	 	

### 5-3. Menu screen

- Press the  key at any screen to return to the home screen.
- The menu screen consists of the following five screens.
- Press the  or  key at a menu screen to change the screen.

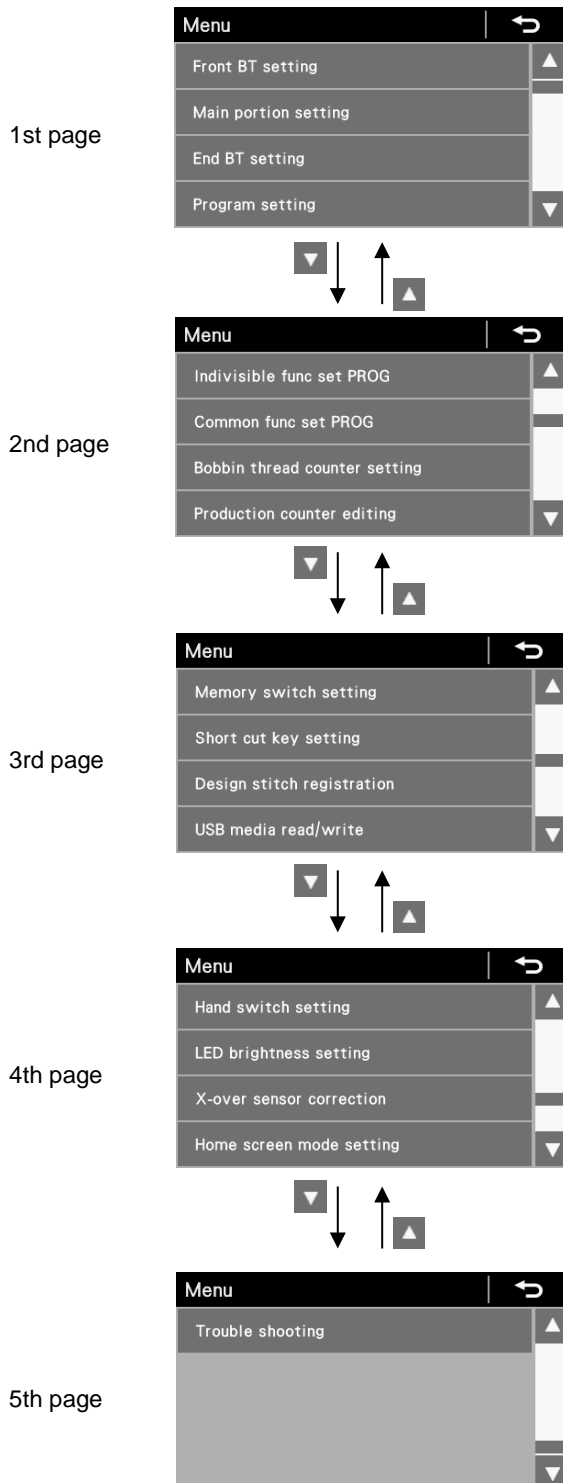

### 5-4. Program setting method

- It is recommended that you register patterns that are sewn frequently as programs. After programs have been registered, you can retrieve the desired sewing patterns simply by selecting a program number, which eliminates the need to set the pattern each time.
- Settings such as sewing pattern, number of stitches, stitch pitch, sewing speed and slow start can be made separately for each program number.
- Up to nine programs from P1 to P9 can be registered.
  - \* At the time of shipment from the factory, P1 to P8 have normal sewing programs registered, and P9 has a 4-step fixed stitch sewing (name label sewing) program registered.

#### 5-4-1. Program structure

- A single program consists of start backtack parameters, main sewing parameters, end backtack parameters and individual functions for that program.

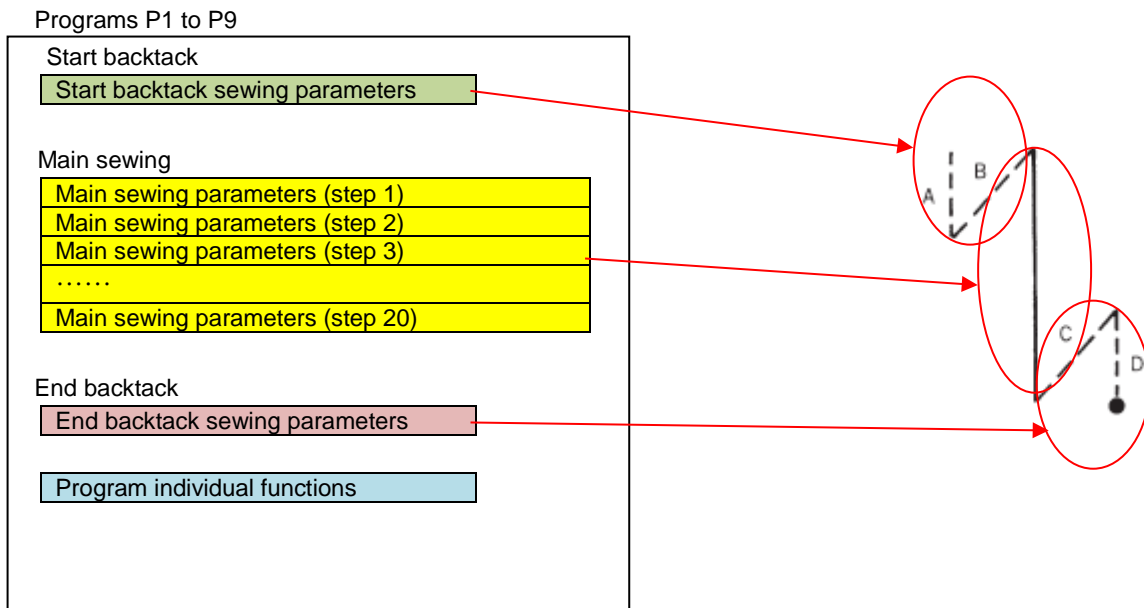

(1) Start backtack sewing parameters

	Setting value
Start backtack sewing pattern	
Sewing speed	220 - 3000 sti/min
No. of stitches A	1 - 19 stitches
No. of stitches B	1 - 19 stitches
Stitch pitch	-3 specifications: 0.05 - 5.00 mm -5 specifications: 0.05 - 5.00 mm

(2) Main sewing parameters



























	Setting value
Main sewing pattern	Normal sewing    Fixed stitch sewing    Reverse fixed stitch sewing  Pleat presser sewing    Continuous backtacking 
Sewing speed	-3 specifications: 220 - 5000 sti/min -5 specifications: 220 - 4500 sti/min
No. of stitches E	1 - 255 stitches
No. of stitches F	1 - 19 stitches
No. of stitches A	0 - 19 stitches
No. of stitches B	1 - 19 stitches
No. of stitches C	1 - 19 stitches
No. of stitches D	0 - 19 stitches
Stitch pitch	-3 specifications: 0.05 - 5.00 mm, DS1 - DS5 (design stitches) -5 specifications: 0.05 - 5.00 mm, DS1 - DS5 (design stitches)

(3) End backtack sewing parameters

	Setting value
End backtack sewing pattern	
Sewing speed	220 - 3000 sti/min
No. of stitches C	1 - 19 stitches
No. of stitches D	1 - 19 stitches
Stitch pitch	-3 specifications: 0.05 - 5.00 mm -5 specifications: 0.05 - 5.00 mm

## 5. USING THE OPERATION PANEL (BASIC OPERATIONS)

### (4) Program individual functions

	Setting value	
Needle up/down	P 	Needle stops in the down position.
	P 	Needle stops in the up position.
Thread trimming lock	P 	Thread trimming operation is carried out when the treadle is depressed backward.
	P 	Thread trimming operation by depressing the treadle backward is locked (disabled).
Thread wiper	P 	Thread wiping disabled
	P 	Thread wiping enabled
Correction sewing	P 	Correction sewing operation using the hand switch is disabled.
	P 	Correction sewing operation using the hand switch is enabled.
AUTO	P 	Normal sewing
	P 	Automatic sewing
	P 	Automatic sewing with thread trimming
Slow start	P 	Slow start disabled at the sewing start
	P 	Slow start enabled at the sewing start (1)
	P 	Slow start enabled at the sewing start (2)
	P 	Slow start enabled at the sewing start (3)
	P 	Slow start enabled at the sewing start (4)
Special locus	P 	The feed dog moves along the standard locus.
	P 	The feed dog moves along special locus 1.
	P 	The feed dog moves along special locus 2.
	P 	The feed dog moves along special locus 3.
Best PFM mode	P 	Best PFM mode disabled
	P 	Best PFM mode enabled (Prev. thread away)
	P 	Best PFM mode enabled (T/T short)
	P 	Best PFM mode enabled (Prev. thread away + T/T short)
X-over seam assist mode	P 	X-over seam assist mode disabled
	P 	X-over seam assist mode enabled

PFM : Performance  
T/T : Thread Trimming  
X-over: Cross-over

5-4-2. Start backtack settings

**1** Switching to start backtack setting mode

**For the detailed home screen**  
If you keep pressing the start backtack key, the display switches to the start backtack setting screen.

**For the simple home screen**  
If you keep pressing the start backtack key, the display switches to the start backtack setting screen.

\* Refer to section 6-5 for details on assigning functions to the shortcut keys.

**For the menu screen**  
Select "Front BT setting" to switch to start backtack setting mode.

---

**2** Set the start backtack sewing parameters.

- (1) Press the [ ◀ ] or [ ▶ ] key to select the start backtack pattern.
- (2) Press the stitch number key to select the number of stitches.  
Use the + and - keys to change the number of stitches.
- (3) Press the stitch pitch key to select the stitch pitch.  
Use the + and - keys to change the value.
- (4) Press the sewing speed key to select the start backtack sewing speed.  
Use the + and - keys to change the value.

---

**3** Press the home key to return to the home screen.  
Press the return key to return to the menu screen (or the home screen).  
\* The settings which are made here are applied to the start backtack key in the home screen.

Start backtack sewing parameters

	Setting value	Setting units	Initial value
Start backtack sewing pattern	A B ↕ A B ↕ <sub>x2</sub> A B ↕ <sub>x3</sub> B ↕ A ↕	—	A B ↕
Sewing speed	220 - 3000 sti/min	100 sti/min	1800
No. of stitches A	1 - 19 stitches	1 stitch	1
No. of stitches B	1 - 19 stitches	1 stitch	1
Stitch pitch	-3 specifications: 0.05 - 5.00 mm -5 specifications: 0.05 - 5.00 mm	0.05 mm	2.00

5-4-3. Main sewing settings

**1** Switching to main sewing setting mode

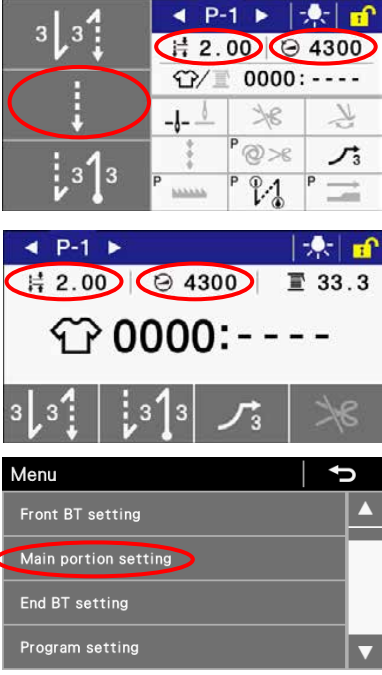

**For the detailed home screen**  
If you keep pressing the main sewing key, stitch pitch key or sewing speed key, the screen will switch to main sewing setting mode.

**For the simple home screen**  
If you keep pressing the stitch pitch key or sewing speed key, the screen will switch to main sewing setting mode.

**For the menu screen**  
Select "Main portion setting" to switch to main sewing setting mode.

**2** Set the main sewing parameters.

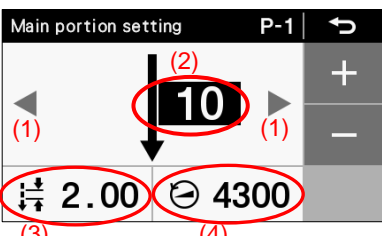

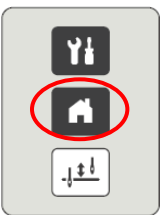

- (1) Press the [ ◀ ] or [ ▶ ] key to select the main sewing pattern.
- (2) Press the stitch number key to select the number of stitches. Use the + and - keys to change the number of stitches.
- (3) Press the stitch pitch key to select the stitch pitch. Use the + and - keys to change the value.
- (4) Press the sewing speed key to select the main pattern sewing speed. Use the + and - keys to change the value.

**3** Press the home key to return to the home screen.  
Press the return key to return to the menu screen (or the home screen).  
\* The settings which are made here are applied to the main sewing key in the home screen.

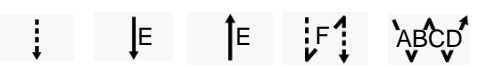

Main sewing parameters

	Setting value	Setting units	Initial value
Main sewing pattern		—	
Sewing speed	-3 specifications: 220 - 5000 sti/min -5 specifications: 220 - 4500 sti/min	100 sti/min	(*1)
No. of stitches E	1 - 255 stitches	1 stitch	1
No. of stitches F	1 - 19 stitches	1 stitch	1
No. of stitches A	0 - 19 stitches	1 stitch	1
No. of stitches B	1 - 19 stitches	1 stitch	1
No. of stitches C	1 - 19 stitches	1 stitch	1
No. of stitches D	0 - 19 stitches	1 stitch	1
Stitch pitch	-3 specifications: 0.05 - 5.00 mm, DS1 - DS5 -5 specifications: 0.05 - 5.00 mm, DS1 - DS5	0.05 mm	2.00

(\*1) For China: 4300 (sti/min)  
For Japan and General Export: 4000 sti/min  
For -3 specifications for Europe and America: 4700 sti/min  
For -5 specifications for Europe and America: 4500 sti/min



### 5-4-4. End backtack settings

<p><b>1</b></p>	<p>Switching to end backtack setting mode</p>	<p><b>For the detailed home screen</b> If you keep pressing the end backtack key, the display switches to the end backtack setting screen.</p> <p><b>For the simple home screen</b> If you keep pressing the end backtack key, the display switches to the end backtack setting screen.</p> <p>* Refer to section 6-5 for details on assigning functions to the shortcut keys.</p> <p><b>For the menu screen</b> Select "End BT setting" to switch to end backtack setting mode.</p>
<p><b>2</b></p>	<p>End BT setting</p>	<p>Set the end backtack sewing parameters.</p> <ol style="list-style-type: none"> <li>(1) Press the [ ◀ ] or [ ▶ ] key to select the end backtack pattern.</li> <li>(2) Press the stitch number key to select the number of stitches. Use the + and - keys to change the number of stitches.</li> <li>(3) Press the stitch pitch key to select the stitch pitch. Use the + and - keys to change the value.</li> <li>(4) Press the sewing speed key to select the end backtack sewing speed. Use the + and - keys to change the value.</li> </ol>
<p><b>3</b></p>		<p>Press the home key to return to the home screen. Press the return key to return to the menu screen (or the home screen). * The settings which are made here are applied to the end backtack key in the home screen.</p>

End backtack sewing parameters

	Setting value	Setting units	Initial value
End backtack sewing pattern		—	
Sewing speed	220 - 3000 sti/min	100 sti/min	1800
No. of stitches C	1 - 19 stitches	1 stitch	1
No. of stitches D	1 - 19 stitches	1 stitch	1
Stitch pitch	-3 specifications: 0.05 - 5.00 mm -5 specifications: 0.05 - 5.00 mm	0.05 mm	2.00

### 5-5. Using program individual functions and program common functions

- In addition to start backtack sewing, main sewing and end backtack sewing, the following 9 types of functions are also included in the parameters which are necessary for sewing.  
Needle up/down, thread trimming lock, thread wiping, correction sewing, AUTO, slow start, special locus, best PFM mode, auto X-over seam assist mode.
- Of these 9 types of functions, the functions which can be set separately for each program are called "program individual" functions.
  - \* When an assignment is made to a program individual function, a "P" symbol appears in the top-left corner of the icon. On the other hand, the functions which can be set in common for all programs (P1 to P9) are called "program common" functions.

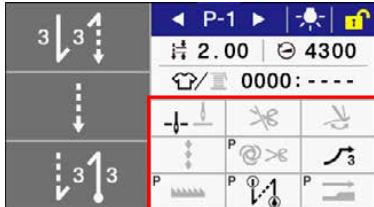

- Each of the 9 types of functions can be set to be used as either a program individual function or a program common function. (Memory switches MSW-301 to MSW-309)

At the time of shipment from the factory, the settings are as follows.

	Program individual functions	Program common function
Needle up/down	×	○
Thread trimming lock	×	○
Thread wiper	×	○
Correction sewing	×	○
AUTO	○	×
Slow start	×	○
Special locus	○	×
Best PFM mode	○	×
X-over seam assist mode	○	×

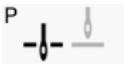
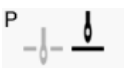

### 5-5-1. Needle up/down

This sets whether the needle bar stops in the up position or the down position when the treadle is returned to the neutral position and sewing stops.

	Setting details
	Needle stops in the down position. However, the needle will stop in the up position when the treadle is depressed backward, and after thread trimming (needle raised) during automatic sewing.
	Needle stops in the up position.



### 5-5-2. Thread trimming lock

This sets the thread trimming operation when the treadle is depressed backward.

	Setting details
	Thread trimming operation is carried out when the treadle is depressed backward.
	Thread trimming operation by depressing the treadle backward is locked (disabled).

### 5-5-3. Thread wiper



Thread wiping operation can be set.

	Setting details
	Thread wiping operation is disabled after thread trimming.
	Thread wiping operation is enabled after thread trimming. * If thread trimming operation is disabled, thread wiping operation will also be disabled.

## 5. USING THE OPERATION PANEL (BASIC OPERATIONS)

### 5-5-4. Correction sewing



Correction sewing operation can be set.

	Setting details
	Correction sewing operation using the hand switch is disabled. <b>NOTE:</b> Operating the hand switch may result in an operation other than correction sewing being carried out. * The operation mode can be changed to a different mode from correction sewing. (Refer to "6-10. Hand switches".)
	Correction sewing operation using the hand switch is enabled. If the sewing machine is stopped, sewing will be carried out at slow speed while the hand switch is being pressed. * The operation mode can be changed to correction sewing. (Refer to "6-10. Hand switches".)

### 5-5-5. AUTO

Automatic sewing and thread trimming operations can be set.

However, they can only be set in conjunction with continuous backtack sewing and fixed stitch sewing.

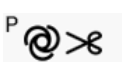
	Setting details
	Automatic sewing is not carried out, and sewing stops when the treadle is returned to the neutral position.
	Sewing is carried out automatically for the number of stitches which have been set (start and end backtacking and fixed stitch sewing) simply by depressing the treadle once. After sewing is complete, depress the treadle backward to carry out thread trimming.
	Sewing is carried out automatically for the number of stitches which have been set (start and end backtacking, fixed stitch sewing, thread trimming) simply by depressing the treadle once. After sewing is complete, thread trimming is carried out automatically.



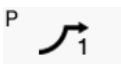
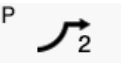
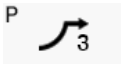
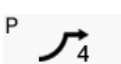

### 5-5-6. Slow start

The slow start pattern at the sewing start after thread trimming can be set.

	Setting details
	Sewing is carried out without slow start operation.
	Sewing is carried out according to slow start pattern 1. 1st stitch: 400sti/min 2nd stitch: 400sti/min 3rd stitch: 400sti/min 4th stitch: 4000sti/min
	Sewing is carried out according to slow start pattern 2. 1st stitch: 400sti/min 2nd stitch: 400sti/min 3rd stitch: 4000sti/min 4th stitch: 4000sti/min
	Sewing is carried out according to slow start pattern 3. 1st stitch: 700sti/min 2nd stitch: 700sti/min 3rd stitch: 4000sti/min 4th stitch: 4000sti/min
	Sewing is carried out according to slow start pattern 4 (original pattern). 1st stitch: Speed set by memory switch MSW-403 2nd stitch: Speed set by memory switch MSW-404 3rd stitch: Speed set by memory switch MSW-405 4th stitch: Speed set by memory switch MSW-406



### 5-5-7. Special locus

The feed dog locus can be set. (Refer to "8-3. Using the feed dog locus".)

	Setting details
	The feed dog moves along the standard locus.
	The feed dog moves along special locus 1.
	The feed dog moves along special locus 2.
	The feed dog moves along special locus 3.

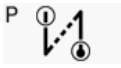

### 5-5-8. Best PFM mode

The treadle can be set to turn the functions for preventing the thread from pulling out ("Prev. thread away" function) and the function for preventing short thread trailing lengths ("T/T short" function) on and off.  
 (The "Prev. thread away" function is added at the sewing start, and the "T/T short" function is added after thread trimming operation.)

	Setting details
	Both the "Prev. thread away" function and the "T/T short" function are disabled.
	The thread pull-out prevention function is enabled.
	The "T/T short" function is enabled.
	Both the "Prev. thread away" function and the "T/T short" function are enabled.

### 5-5-9. X-over seam assist mode

X-over seam sewing using the X-over seam sensor can be set to on or off.

	Setting details
	X-over seam assist is disabled (normal sewing is carried out).
	X-over seam assist is enabled. When the X-over seam sensor detects an X-over seam, the sewing speed, feed locus, feed timing and stitch pitch are changed to the special settings for X-over seam sewing.

## 5-6. Using the production counter

- The production counter can be used to let you know how many items have been sewn.
- The production counter increases by 1 each time thread trimming is carried out.

1

Switching to production counter editing mode

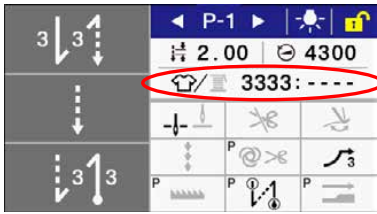

### For the detailed home screen

Set the counter display so that it is displaying the production counter icon, and then keep pressing the production counter key to switch to production counter editing mode.

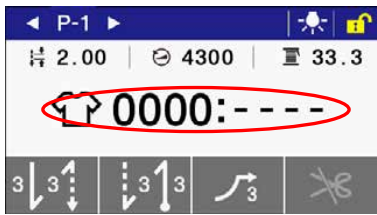

### For the simple home screen

Keep pressing the production counter key to switch to production counter editing mode.

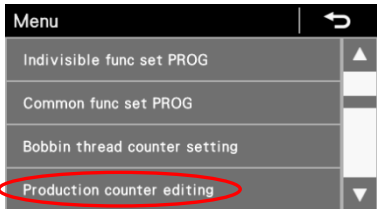

### For the menu screen

Select "Production counter editing" to switch to the production counter editing screen.

2

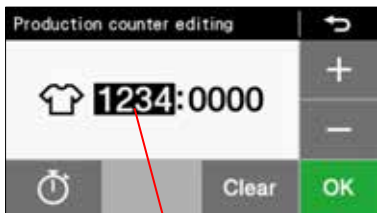





(1)

- Use the + and - keys to change the value of the production counter (1). When the value is changed, the production counter (1) will flash.
- If you would like to return the setting to "0000", press the Clear key.
- If you press the OK key, the value will be confirmed and the display will return to the home screen.

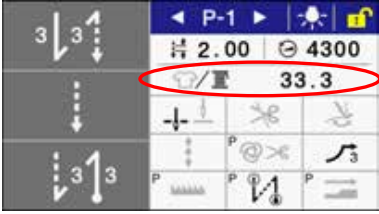
## 5-7. Using the lower thread counter

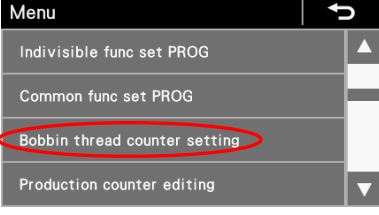
- The lower thread counter can be used to let you know approximately how much lower thread is remaining.
- \* The lower thread counter should be used as a guide only.
- The value displayed by the lower thread counter display is reduced by 0.1 from the initial setting value each time the number of stitches x sewing pitch reaches 0.1 m, and a warning is given when the counter goes below 0.

<p><b>1</b></p>	<p>Switching to lower thread counter setting mode</p>  <p><b>For the detailed home screen</b> Set the counter display so that it is displaying the lower thread counter icon, and then keep pressing the lower thread counter key to switch to lower thread counter setting mode.</p>  <p><b>For the simple home screen</b> Keep pressing the lower thread counter key to switch to lower thread counter setting mode.</p>  <p><b>For the menu screen</b> Select "Bobbin thread counter setting" to switch to lower thread counter setting mode.</p>	<p><b>For the menu screen</b> Select "Bobbin thread counter setting" to switch to lower thread counter setting mode.</p>
<p><b>2</b></p>	 <p>(1)</p>	<ul style="list-style-type: none"> <li>• You can use the ON/OFF key to turn the counter function on and off.</li> <li>* When the function is turned off, "---" will appear in the counter display (1) and the counter will not operate while sewing is carried out.</li> <li>• Use the + and - keys to set the value for the lower thread counter. When the value is changed, the lower thread counter (1) will flash. The setting range is from 0.1 to 99.9 m.</li> <li>• You can press the Reset key to provisionally reset the value to the one which was set previously (only if the counter function was turned on).</li> <li>• If you press the OK key, the value will be confirmed and the display will return to the home screen.</li> </ul>



<Lower thread counter operation>

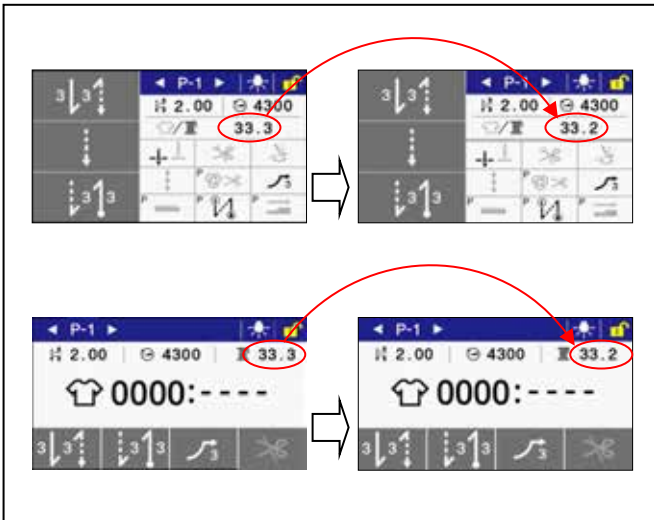

When sewing is carried out, the value shown in the lower thread counter display is reduced by 0.1 each time the number of stitches x sewing pitch reaches 0.1 m. However, the display is only updated when the treadle is returned to the neutral position.

<Lower thread out warning when sewing stops (before thread trimming)>

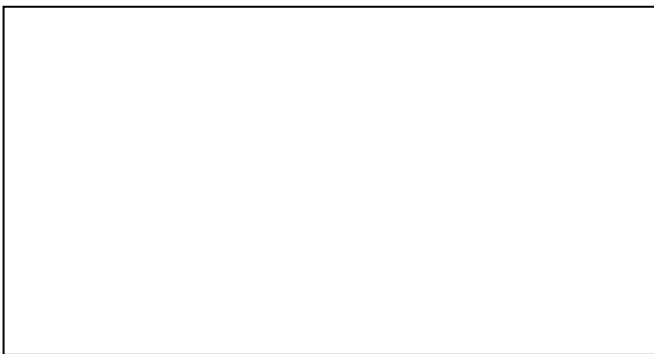

1. If the lower thread counter has dropped to below 0 when the sewing machine stops sewing, the warning buzzer sounds 5 times (1 second on/1 second off), and a lower thread counter warning message is displayed.
  - \* Sewing will not be possible even if the treadle is depressed forward.
2. **<If replacing the bobbin>**
  - (1) Depress the treadle backward to trim the thread.
  - (2) Replace the bobbin.
  - (3) Press the Reset key.
    - \* The lower thread counter value will return to the value which was previously set.
- <If not replacing the bobbin>**
  - (1) Press the return key.
    - \* The lower thread counter value will remain unchanged.
3. The display will return to the screen which was being displayed before the lower thread counter out warning appeared, and sewing will be possible.

<Lower thread out warning when sewing is complete (after thread trimming)>



1. If the lower thread counter has dropped to below 0 after sewing is complete, the warning buzzer sounds 5 times (1 second on/1 second off), and a lower thread counter warning message is displayed.
  - \* Sewing will not be possible even if the treadle is depressed forward.
2. Replace the bobbin.
3. Press the Reset key.
  - \* The lower thread counter value will return to the value which was previously set.
4. The display will return to the screen which was being displayed before the lower thread counter out warning appeared, and sewing will be possible.

## 5-8. Home screen mode setting

- You can select from two different types of home screen display: the detailed home screen or the simple home screen.
- \* When the home screen is displayed, you can keep pressing the  key to switch between home screens.

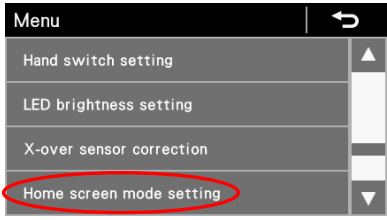
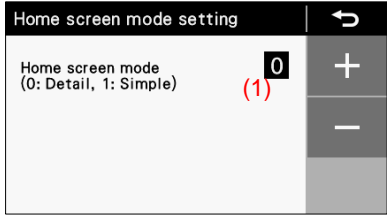
<b>1</b>		Switching to home screen mode setting mode At the menu screen, select "Home screen mode setting" to switch to home screen mode setting mode.
<b>2</b>		Use the + and - keys to set the value (1) for the mode. <ul style="list-style-type: none"><li>• Press the return key to return to the menu screen.</li><li>• Press the home key to return to the home screen which has been set.</li></ul>

## 5-9. Illumination LED brightness setting

The brightness of the illumination LED can be set.

1

Switching to illumination LED brightness setting mode

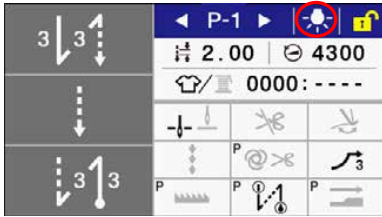

**For the detailed home screen**

Keep pressing the "LED brightness" key to switch to illumination LED brightness setting mode.



**For the simple home screen**

Keep pressing the "LED brightness" key to switch to illumination LED brightness setting mode.

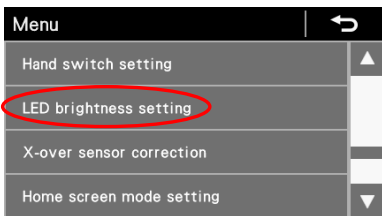

**For the menu screen**

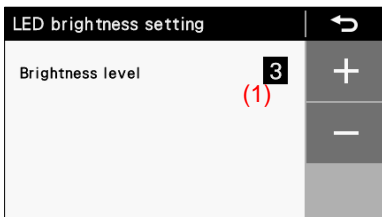

Select "LED brightness setting" to switch to illumination LED brightness setting mode.

2



Use the + and - keys to set the value for the brightness level (1).

The setting range is from 1 to 9.





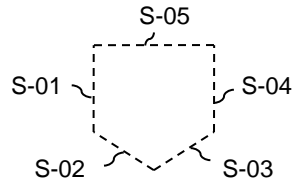

- Press the home key to return to the home screen.
  - Press the return key to return to the menu screen (or the home screen).
- \* Once the value for the brightness level is changed, the  status will be displayed when you return to the home screen, even if the  status was being displayed previously.

# 6. USING THE OPERATION PANEL (ADVANCED OPERATIONS)

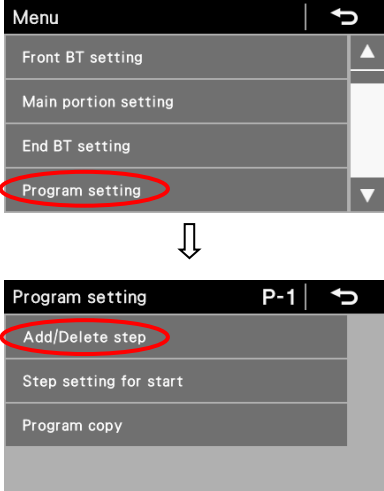
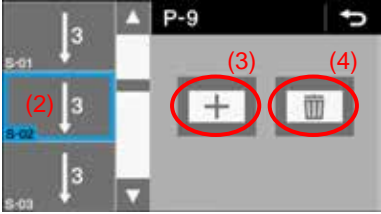
## 6-1. Adding and deleting steps

You can put together programs, such as the one shown in the illustration at right for pocket sewing, by registering multiple steps in the main sewing section.



<p><b>1</b></p>	<p>Switching to add/delete step mode</p>  <p>1. At the menu screen, select "Program setting" to switch to program setting mode.</p> <p>2. Next, in program setting mode, select "Add/Delete step" to switch to add/delete step mode.</p>
<p><b>2</b></p>	<p><b>&lt;Add/delete step mode&gt;</b> Steps can be added (up to a maximum of 20 steps) to or deleted (to a minimum of 1 step) from the currently-selected program. However, if fixed stitch sewing or reverse fixed stitch sewing is not selected, it will not be possible to switch to this mode.</p>  <ul style="list-style-type: none"> <li>The program number (1), step number (2), sewing pattern and cursor (blue box) for the currently-selected program are displayed.</li> <li>Press the  or  key to change the cursor position.</li> </ul> <p>★ <b>When adding a step</b> Press the  key (3) to add a step after the current cursor position. The sewing pattern for the added step will be the fixed stitch sewing pattern. However, if the number of steps has already reached 20, no further steps can be added.</p> <p>★ <b>When deleting a step</b> Press the  key (4) to delete the step at the current cursor position. However, if only 1 step is remaining, the delete key will be disabled.</p>
<p><b>3</b></p>	 <p>Press the return key to return to the program setting screen. Press the menu key to return to the menu screen. Press the home key to return to the home screen.</p> <p>* When more than one step had been added for sewing, the number of stitches in the step which is currently being sewn will be completed, and then sewing will continue on to the next step.</p>

## 6-2. Editing steps

The number of stitches and sewing pitch can be changed separately for each step.

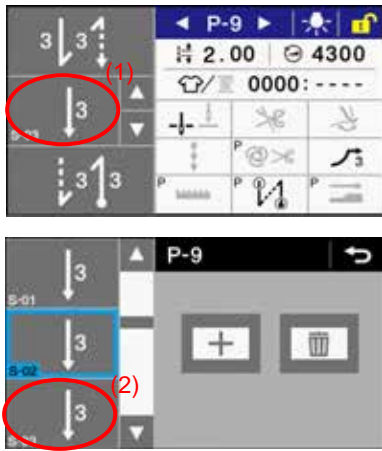
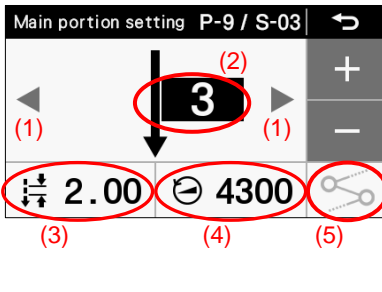
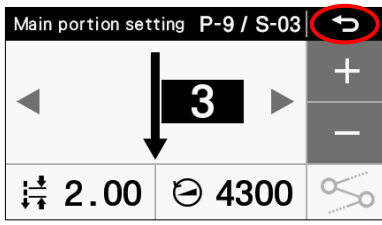
<p><b>1</b></p>	<p>Switching to main sewing setting mode</p> 	<p><b>From the detailed home screen</b></p> <ul style="list-style-type: none"> <li>Press the  or  key to select the step number to be edited.</li> <li>Keep pressing the main sewing key (1) to switch to main sewing setting mode.</li> </ul> <p><b>From add/delete step mode</b></p> <ul style="list-style-type: none"> <li>Press the  or  key to display the number of the step to be edited.</li> <li>Press the pattern (2) for the step number to be edited to switch to main sewing setting mode.</li> </ul>
<p><b>2</b></p>	<p>Main portion setting P-9 / S-03</p> 	<p>Set the main sewing parameters.</p> <ol style="list-style-type: none"> <li>Press the  or  key to select the main sewing pattern.</li> <li>Press the stitch number key to select the number of stitches. Use the + and - keys to change the number of stitches.</li> <li>Press the stitch pitch key to select the stitch pitch. Use the + and - keys to change the value.</li> <li>Press the sewing speed key to select the main pattern sewing speed. Use the + and - keys to change the value.</li> <li>Press the link key to switch linking between enabled and disabled.   : No linking with next step   : Linking with next step</li> </ol>
<p><b>3</b></p>	<p>Main portion setting P-9 / S-03</p> 	<p>Press the return key to return to the previous screen.</p>

Main sewing parameters when several steps exist

	Setting value	Setting units	Initial value
Main sewing pattern	E E	—	E
Sewing speed	-3 specifications: 220 - 5000 sti/min -5 specifications: 220 - 4500 sti/min	100 sti/min	(*1)
No. of stitches E	1 - 255 stitches	1 stitch	1
Stitch pitch	-3 specifications: 0.05 - 5.00 mm, DS1 - DS5 -5 specifications: 0.05 - 5.00 mm, DS1 - DS5	0.05 mm	2.00
Linking		—	

(\*1) For China: 4300 (sti/min)

For Japan and General Export: 4000 sti/min

For -3 specifications for Europe and America: 4700 sti/min

For -5 specifications for Europe and America: 4500 sti/min

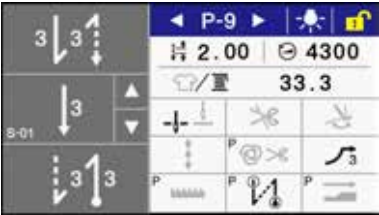
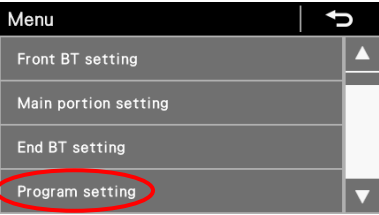
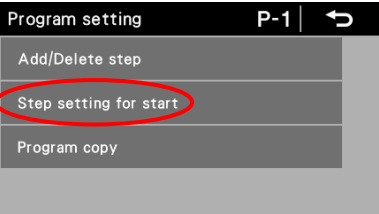
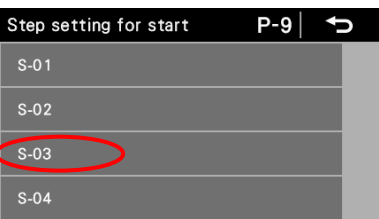
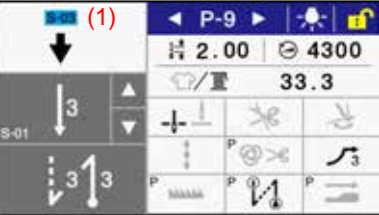

### 6-3. Sewing start step setting

If sewing is interrupted by a problem such as a thread breakage occurring and you need to resume sewing from the point where sewing was interrupted, you can start sewing from the middle of a step.

<p><b>1</b></p>	<p>Switching to sewing start step setting mode</p>  <p>↓</p>  <p>↓</p> 	<ol style="list-style-type: none"> <li>1. At the detailed home screen, press the menu key.</li> <li>2. At the menu screen, select "Program setting" to switch to program setting mode.</li> <li>3. Next, in program setting mode, select "Step setting for start" to switch to sewing start step setting mode.</li> </ol>
<p><b>2</b></p>		<ul style="list-style-type: none"> <li>• Select the step number for the step where you would like sewing to start from.</li> </ul>
<p><b>3</b></p>		<ul style="list-style-type: none"> <li>• The step number (1) for starting sewing will be displayed.</li> <li>• Depress the treadle to start sewing from that step. When sewing is finished, the sewing start step number (1) is cleared and the display returns to the normal detailed home screen.</li> <li>* If the program number is changed or the power is turned off and back on, the sewing start step number (1) will be cleared even if sewing is not carried out.</li> </ul>

## 6-4. Program copy

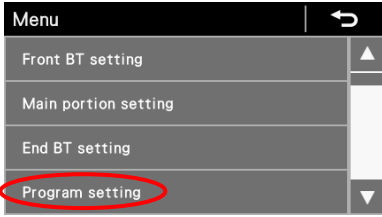
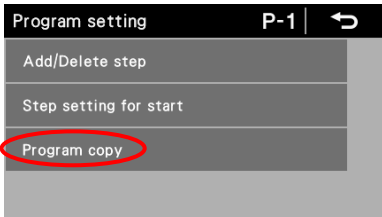
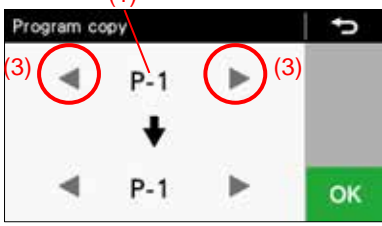
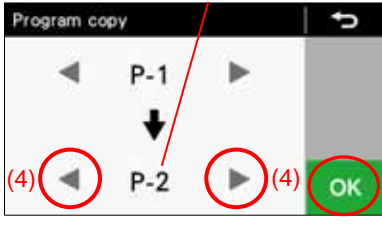
To create a program with parameters that are almost exactly the same as those of another program, you can copy the original program and change just the parts which need to be changed.

<p><b>1</b></p>	<p>Switching to program copy mode</p>  	<p>1. At the menu screen, select "Program setting" to switch to program setting mode.</p> <p>2. Next, in program setting mode, select "Program copy" to switch to program copy mode.</p>
<p><b>2</b></p>	  	<ul style="list-style-type: none"> <li>• After switching to program copy mode, the program number which is currently selected is displayed as the copying source program number (1) and as the copying destination program number (2).</li> <li>• Press the ◀ or ▶ key (3) to select the copying source program number (1).</li> <li>• Press the ◀ or ▶ key (4) to select the copying destination program number (2).</li> <li>• When you press the OK key, the program will be copied.</li> <li>* At this time, the copy destination program number will be the program number which is currently selected.</li> </ul>
<p><b>3</b></p>		<p>Press the return key to return to the program setting screen. Press the menu key to return to the menu screen.</p>

## 6-5. Shortcut key assignment method

You can assign functions to the 4 shortcut keys which are displayed on the simple home screen. Initially, the start backtick key, end backtick key, slow start key and thread trimming lock key are assigned.

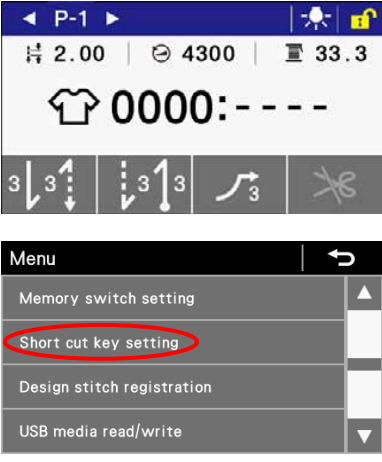
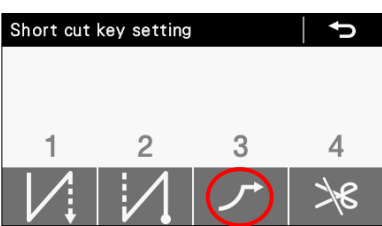
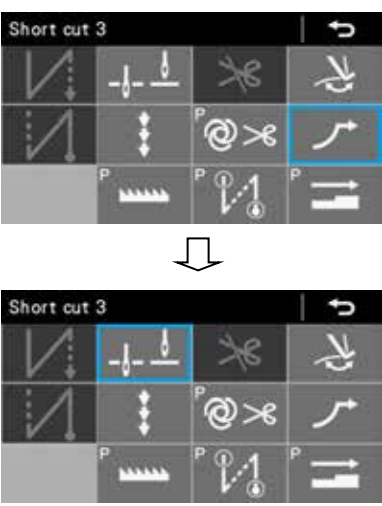
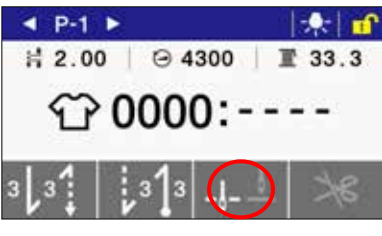
<p><b>1</b></p>		<p>At the menu screen, select "Short cut key setting" to switch to shortcut key setting mode.</p>
<p><b>2</b></p>	<p>&lt;Shortcut key setting mode (key selection)&gt;</p>  <p>&lt;Shortcut key setting mode (function selection)&gt;</p> 	<p>1. At the shortcut key setting mode (key selection) screen, select the shortcut key (1 to 4) which you would like to assign a function to.</p> <p>2. At the shortcut key setting mode (function selection) screen, select the function which you would like to assign to the shortcut key. The currently-selected icon will be enclosed in a blue box.</p>
<p><b>3</b></p>		<p>After a shortcut key has been assigned, press the home key to return to the simple home screen. The icon for the function which has been assigned to the shortcut key will be displayed in this screen.</p>



## 6-6. Design stitch registration method

Up to 5 different types of design stitches (DS-1 to DS-5), each one consisting of several different pitch groups (up to a maximum of 8 groups), can be registered.

A single group can be set to contain up to a maximum of 20 stitches with the same stitch pitch.

This section shows an example of how to register a design stitch which contains the following eight kinds of stitches into DS-1.

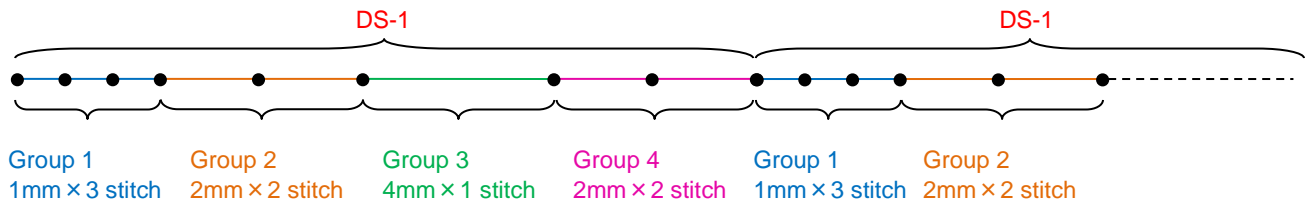

1

Switching to add/delete step mode

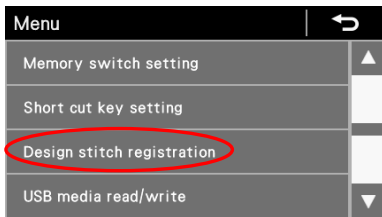

1. At the menu screen, select "Design stitch registration" to switch to the design stitch registration (number selection) screen.



2. Next, select the design stitch number to be registered from DS-1 to DS-5.

## 6. USING THE OPERATION PANEL (ADVANCED OPERATIONS)

2

<Design stitch registration (content setting) screen>

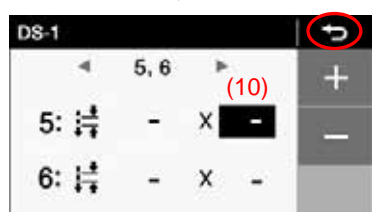
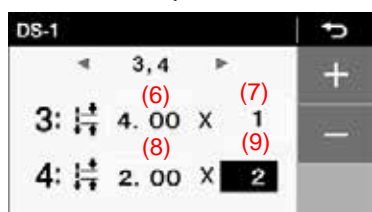
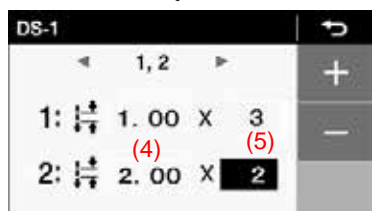
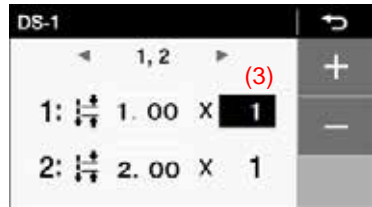
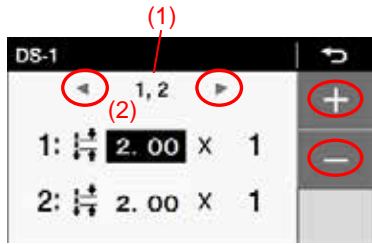

The design stitch number (1) to be registered will be displayed.

1. Press the ◀ or ▶ key to change the group number (1).
2. Press the + or - key to set the stitch pitch (2) for group 1 to 1.00 mm. The stitch pitch can be set to between 0.05 mm and 5.00mm. The initial setting is 2.00 mm.
3. Touch the number of stitches (3) for group 1.
4. Press the + or - key to change the number of stitches (3) for group 1 to 3 stitches. The number of stitches can be set to between 0 and 20 stitches. The initial setting is 1 stitch.

5. Change the following in the same way.

For group 2, set the sewing pitch (4) to 2.00 mm and the number of stitches (5) to 2;

For group 3, set the sewing pitch (6) to 4.00mm and the number of stitches (7) to 1;

For group 4, set the sewing pitch (8) to 2.00 mm and the number of stitches (9) to 2;

For group 5, change the number of stitches (10) to "-" (no stitches).

\* If the number of stitches is set to "-", all of the subsequent numbers of stitches will be set to "-".

6. Press the return key to return to the design stitch registration (number selection) screen.

Press the menu key to return to the menu screen.

Press the home key to return to the home screen.





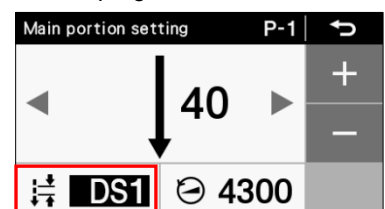

★ In order to sew design stitches, it is necessary to put the design stitches registered above into a program.

1. At the home screen, select the desired program number.
2. The display will switch to the main sewing setting screen.
3. Select the stitch pitch, and then press the + or - key to set the desired design stitch.  
\* For DS1 to DS5, the maximum stitch pitch is displayed as follows.
4. Press the home key to return to the home screen.

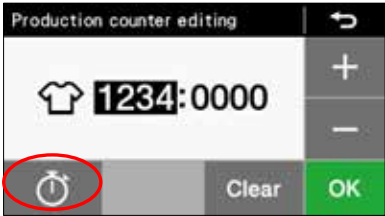

## 6-7. Working pace setting method

- The target counter can be used to let you know the state of work progress.
- The target counter increases by 1 each time the time set as the working pace has elapsed.  
However, counting is not carried out during the period from when the power is turned on until sewing starts.

<p><b>1</b></p>	<p>Switching to working pace setting mode</p> 	<ul style="list-style-type: none"> <li>• In production counter editing mode, press the  key to switch to working pace setting mode.</li> <li>* The target counter cannot be edited. The target counter can be reset to "0000" only by clearing the production counter.</li> </ul>
<p><b>2</b></p>	<p>&lt;Working pace setting mode&gt; In this mode, you can set the pace at which the target counter increases. * If the operating status (1) for the target counter is set to OFF, the target counter function will not operate. It will not be possible to set the working pace at this time either.</p> 	<ul style="list-style-type: none"> <li>• Press the  key (1) to set the operating status to  so that the working pace can be set.</li> </ul>
<p><b>3</b></p>	<p>The working pace (2) will be displayed. The working pace can be set to between 00'01" and 59'59".</p> 	<ul style="list-style-type: none"> <li>• Press the + key to increase the value, and press the - key to decrease the value. If the setting is changed to a value which is different to the value which was set previously, the time display will flash. If you would like to return the setting to the value which was set previously, press the Reset key.</li> </ul>
<p><b>4</b></p>	<p>&lt;Exiting working pace setting mode&gt;</p> 	<ul style="list-style-type: none"> <li>• To confirm the setting and exit, press the OK key. The working pace will be confirmed and the mode will return to production counter setting mode.</li> <li>• To exit without confirming the setting, press the return key. The mode will return to production counter editing mode.</li> </ul>

## 6-8. Memory switch setting method (Standard)

- The settings for the memory switches are valid for all programs.

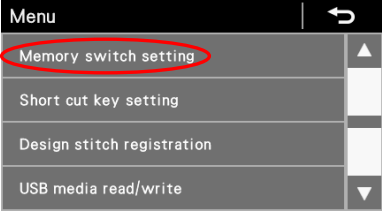
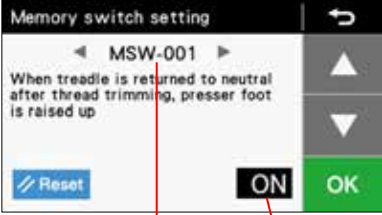
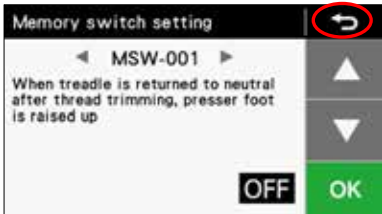
<p><b>1</b></p>	<p>&lt;Switching to memory switch setting mode (Standard)&gt;</p> 	<p>At the menu screen, select "Memory switch setting" to switch to memory switch setting mode.</p>
<p><b>2</b></p>	<p>&lt;Memory switch setting mode&gt;</p> 	<ol style="list-style-type: none"> <li>Press the ◀ or ▶ key to select the memory switch number (1). At this time, keep pressing the half stitch key and then press the ◀ or ▶ key at the same time to select only the memory switches with current values that are different from their initial values.</li> <li>Press the ▼ or ▲ key to change the memory switch value (2). If the value that is displayed is different from the value that is currently set, the value in the display will flash. If you would like to return the setting to the initial value, press the Reset key. * The Reset key is only displayed when the setting value (the value being displayed) is different from the initial value.</li> <li>Press the OK key to store the memory switch setting. The setting display will change from flashing to illuminated.</li> </ol>
<p><b>3</b></p>	<p>&lt;Memory switch setting mode exiting method&gt;</p> 	<p>Press the return key to return to the menu screen.</p>

## 6-9. List of memory switch settings

Presser foot lifter and treadle settings (001 to 099)

No.	Setting range	Initial value	Setting units	Setting details
001	ON/OFF	(*1)	—	When treadle is returned to neutral after thread trimming, presser foot is raised up ON: Presser foot is raised OFF: Presser foot is not raised (* ) The presser foot lifts when MSW-851 is set to "OFF". (Refer to the Service Manual for details on MSW-851.)
002	ON/OFF	OFF	—	After treadle stops at neutral, presser foot is raised up ON: Presser foot lifts OFF: Presser foot is not lifted
003	ON/OFF	ON	—	After treadle stops at neutral, presser foot is possible to raised up when treadle depressed one step backward. ON : Enabled OFF: Disabled
004	ON/OFF	ON	—	When treadle depressed backward, thread trimming and end backtack sewing is possible. ON: Thread trimming and end backtack sewing operations are enabled (However, if thread trimming operation is locked, needle up operations will be carried out without thread trimming.) OFF: Thread trimming and end backtack sewing operations are disabled (presser foot lifts when the treadle is depressed backward)
010	ON/OFF	OFF	—	After standing up pedal is used, treadle operation is possible. (Alternating operation is possible) (* ) For simultaneous operation which includes operation of the presser foot lifter pedal, operation of the standing operation pedal takes priority. ON: Treadle operation is still enabled after standing operation pedal has been used (alternating operation is possible) OFF: Treadle operation is disabled after standing operation pedal has been used
011	0 - 1	0	1	Operation when standing up variable speed pedal is ON 0: Sewing speed corresponds to treadle depression amount 1: Sewing speed corresponds to sewing speed set for main sewing (constant speed)
012	0 - 500 (ms)	80 (ms)	10 (ms)	Delay time from standing pedal turning on until motor starts operating
013	ON/OFF	ON	—	When AUTO function is set ON, pauses when presser foot pedal is ON. ON: Sewing is interrupted when presser foot lifter pedal turns on (pause operation) OFF: No operation
014	ON/OFF	ON	—	When AUTO function is set ON, it can be changed ON/OFF of motor operation by slightly pressing high speed pedal. ON: Motor operation switches on/off each time the high-speed pedal is depressed slightly to ON and back to OFF OFF: Disabled (sewing machine motor does not stop)
015	ON/OFF	ON	—	After thread trimming, possible to lift up and down by thread trimming pedal ON: Presser foot can be raised and lowered (* ) If MSW-051 is set to "ON", thread trimming pedal operation is disabled after the presser foot lifter pedal has been operated during standing operation. (Refer to the Service Manual for details on MSW-051.) OFF: No operation (only possible using presser foot lifter pedal)

(\*1) Other than Europe and America: ON  
Europe and America: OFF

## 6. USING THE OPERATION PANEL (ADVANCED OPERATIONS)

### Sewing machine motor settings (100 to 199)

No.	Setting range	Initial value	Setting units	Setting details
100	OFF, 1 - 3	OFF	1	Slow control after sewing start OFF: Disabled 1: Only at the sewing start after thread trimming 2: Only when sewing is restarted 3: Usual operation
101	1 - 5	1	1	Degree of slow startup immediately after sewing start (A larger number means a slower startup) * This is not displayed when MSW-100 is set to "OFF".
102	-10 - 10 (Degrees)	0 (Degrees)	1	Needle up stop position correction value
103	-10 - 10 (Degrees)	0 (Degrees)	1	Needle down stop position correction value

### Feed motor settings (200 to 299)

No.	Setting range	Initial value	Setting units	Setting details
200	50 - 150%	100	1	Forward direction pitch correction ratio
201	50 - 150%	100	1	Reverse direction pitch length correction ratio

## 6. USING THE OPERATION PANEL (ADVANCED OPERATIONS)

### Panel operation settings (300 to 399)

No.	Setting range	Initial value	Setting units	Setting details
300	1 - 2	1	1	Movement when bobbin counter warning. 1: Sewing can continue by pressing the return key 2: Sewing is only possible when lower thread counter is reset after replacing the bobbin.
301	0, 1	0	1	Program common function / program individual function settings Needle up/ down 0: Program common function 1: Program individual function
302	0, 1	0	1	Program common function / program individual function settings Thread trimming lock 0: Program common function 1: Program individual function
303	0, 1	0	1	Program common function / program individual function settings Thread wiper 0: Program common function 1: Program individual function
304	0, 1	0	1	Program common function / program individual function settings Correction sewing 0: Program common function 1: Program individual function
305	0, 1	1	1	Program common function / program individual function settings AUTO/ auto thread trimming 0: Program common function 1: Program individual function
306	0, 1	0	1	Program common function / program individual function settings Slow start 0: Program common function 1: Program individual function
307	0, 1	1	1	Program common function / program individual function settings Special locus 0: Program common function 1: Program individual function
308	0, 1	1	1	Program common function / program individual function settings Best PFM mode 0: Program common function 1: Program individual function
309	0, 1	1	1	Program common function / program individual function settings X-over seam assist mode 0: Program common function 1: Program individual function
310	OFF, 30 - 300 (sec)	60	30	Automatic panel lock ON standby time OFF: Automatic panel lock is disabled 30 - 300: Panel open time before panel lock turns on (sec) * The standby time is only counted at the home screen. If any other screen is displayed, the panel lock does not operate.
311	OFF, ON	ON	—	Panel auto lock when turn on power OFF: Disabled ON : Enabled

## 6. USING THE OPERATION PANEL (ADVANCED OPERATIONS)

### Sewing program settings (400 to 499)

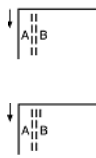
No.	Setting range	Initial value	Setting units	Setting details
400	ON/OFF	OFF	—	Stopping during start backtacking and sewing speed ON: When the treadle is returned to the neutral position, start backtacking can be stopped before it is finished, and the speed during start backtacking becomes the speed corresponding to the treadle depression amount (low speed - start backtacking speed) OFF: When the treadle is returned to the neutral position, start backtacking ends, sewing stops and the sewing speed becomes the start backtacking speed (constant)
401	ON/OFF	ON	—	Feed direction when sewing machine motor is stopped immediately after start backtacking is complete OFF: Sewing machine motor stops after start backtacking is complete * If MSW-400 is set to "OFF", operation occurs when the treadle is depressed slightly. ON: After start backtack sewing, the feed moves forward, then the sewing machine motor stops. 
402	1 - 2	1	1	Fixed stitch sewing load FUNC when stitch control in reverse direction. 1: Reverse stitch sewing when hand switch is ON 2: Fixed stitch sewing when hand switch is ON
403	300 - 4000 (sti/min)	4000	100	1st stitch sewing speed for slow start original pattern
404	300 - 4000 (sti/min)	4000	100	2nd stitch sewing speed for slow start original pattern
405	300 - 4000 (sti/min)	4000	100	3rd stitch sewing speed for slow start original pattern
406	300 - 4000 (sti/min)	4000	100	4th stitch sewing speed for slow start original pattern
407	ON/OFF	OFF	—	Synchronize with main pitch of backtack sewing pitch ON: Synchronized OFF: Not synchronized

### Standard device settings (500 to 599)

No.	Setting range	Initial value	Setting units	Setting details
500	OFF, 1 - 3	1	1	Presser foot lifter SW function OFF: Disabled 1: Presser foot lifter switch 2: Puller switch (alternate) 3: Puller switch (momentary) * Puller operation is enabled when MSW-960 is set to "1" (it does not operate when set to other than "2" or "3"). (Refer to the Service Manual for details on MSW-960.) * If set to puller switch, the presser foot lifting function using the switch is disabled.



## 6-10. Hand switches

There are two types of hand switch: Type A and type B. The following functions can be assigned to each one.

\* However, they cannot both be pressed at the same time. (The one which was pressed first will be activated.)

The input for hand switch A is in 8 steps, and the input for hand switch B is in 3 steps (off, half-pressed and fully-pressed).

(The operation of the hand switches will vary depending on the status of the correction sewing icon.)

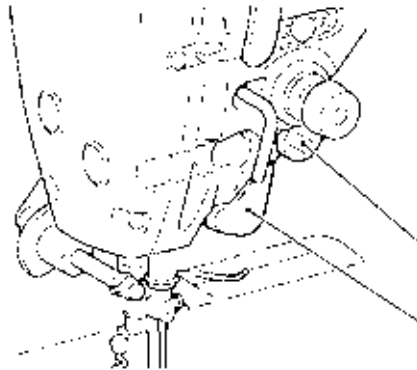

Hand switch A

Hand switch B

0936D

	Hand switch A (initial value: 1)	Hand switch B (initial value: 1)
Settings for correction sewing switch	OFF: <Disabled>	OFF: <Disabled>
	1: <Single stitch correction sewing at 2nd correction pitch> Stops after sewing a single stitch * Set the 2nd correction pitch separately.	1: <Single correction sewing> Stops after sewing a single stitch
	2: <Continuous correction sewing at 2nd correction pitch> If the switch is kept pressed, sewing continues. * Set the 2nd correction pitch separately.	2: <One pitch /Continuous correction sewing> Half pressed: Stops after sewing a single stitch Fully pressed: If the switch is kept pressed, sewing continues.
	3: <Single correction sewing> Stops after sewing a single stitch	3: <Continuous correction sewing> If the switch is kept pressed, sewing continues.
	4: <Continuous correction sewing> If the switch is kept pressed, sewing continues.	4: <Single stitch correction sewing at 2nd correction pitch> Stops after sewing a single stitch * Set the 2nd correction pitch separately.
	5: <Reverse single correction sewing> Stops after sewing a single stitch	5: <One pitch at second correction pitch/ continuous correction sewing> Half pressed: Stops after sewing a single stitch Fully pressed: If the switch is kept pressed, sewing continues. * Set the 2nd correction pitch separately.
	6: <Reverse continuous correction sewing> If the switch is kept pressed, sewing continues.	6: <Continuous correction sewing at 2nd correction pitch> If the switch is kept pressed, sewing continues. * Set the 2nd correction pitch separately.
	7: <Single correction sewing> Stops after half stitch sewing	7: <Reverse single correction sewing> Stops after sewing a single stitch
		8: <Reverse one pitch/ reversed continuous correction sewing> Half pressed: Stops after sewing a single stitch Fully pressed: If the switch is kept pressed, sewing continues.
		9: <Reverse continuous correction sewing> If the switch is kept pressed, sewing continues.
	10: <Single correction sewing> Stops after half stitch sewing	

\* These settings are enabled when the correction sewing icon is illuminated (  ).

## 6. USING THE OPERATION PANEL (ADVANCED OPERATIONS)

	Hand switch A (initial value: 4)	Hand switch B (initial value: 1)
Settings for other than correction sewing switch	OFF: <Disabled>	OFF: <Disabled>
	1: <Variable pitch (reverse is available)> Sewing pitch changes from main pitch to reverse main pitch depending on how far the switch is pressed.	1: <Reverse> Feed moves in reverse while the switch is being pressed.
	2: <Variable pitch (reverse unavailable)> Sewing pitch changes from main pitch to 0 pitch depending on how far the switch is pressed.	2: <Second pitch/ reversed> Half pressed: Changes to 2nd pitch while the switch is being pressed. Fully pressed: Feed moves in reverse while the switch is being pressed. * Set the second pitch separately.
	3: <Reverse> Feed moves in reverse while the switch is being pressed.	3: <Second Pitch> Changes to 2nd pitch while the switch is being pressed. * Set the second pitch separately.
	4: <Second Pitch> Changes to 2nd pitch while the switch is being pressed. * Set the second pitch separately.	4: <Second Pitch (switching)> Switches between second pitch and main pitch each time the switch is pressed. * Set the second pitch separately.
	5: <Second Pitch (switching)> Switches between second pitch and main pitch each time the switch is pressed. * Set the second pitch separately.	5: <X-over seam assist> X-over seam assist is carried out while the switch is being pressed. Special locus 3 and X-over assist parameters are used during X-over seam sewing. Changes to special locus 3 while the switch is being pressed.
	6: <X-over seam assist> X-over seam assist is carried out while the switch is being pressed. Special locus 3 and X-over assist parameters are used during X-over seam sewing. Changes to special locus 3 while the switch is being pressed.	6: <Auto X-over seam assist (switching)> Switches between X-over seam assist and normal sewing each time the switch is pressed. Special locus 3 and X-over assist parameters are used during X-over seam assist.
	7: <Auto X-over seam assist (switching)> Switches between X-over seam assist and normal sewing each time the switch is pressed. Special locus 3 and X-over assist parameters are used during X-over seam assist.	7: <Thread trimming> When the switch is pressed, thread trimming is carried out. * When this function is selected, the hand switch operates as a thread trimming switch even if the correction sewing icon is turned on.
	8: <Thread trimming> When the switch is pressed, thread trimming is carried out. * When this function is selected, the hand switch operates as a thread trimming switch even if the correction sewing icon is turned on.	8: <Presser foot lifter> If the switch is pressed while tread trimming is stopped, the presser foot is raised.
	9: <Presser foot lifter> If the switch is pressed while tread trimming is stopped, the presser foot is raised.	9: <Presser foot lifter (switching)> While tread trimming is stopped, the presser foot is raised and lowered each time the switch is pressed.
10: <Presser foot lifter (switching)> While tread trimming is stopped, the presser foot is raised and lowered each time the switch is pressed.		

\* These settings are enabled when the correction sewing icon is turned off (  ).

## 6-10-1. Hand switch function setting

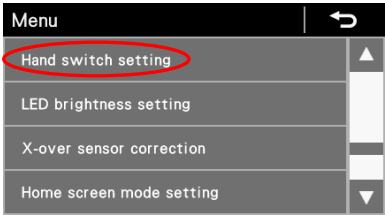
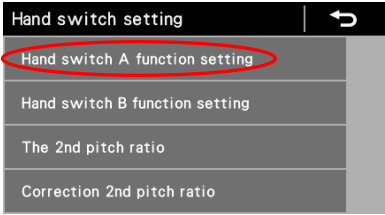
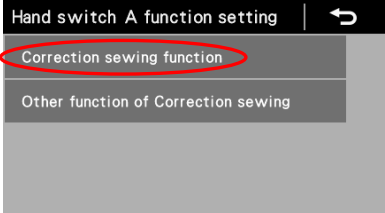
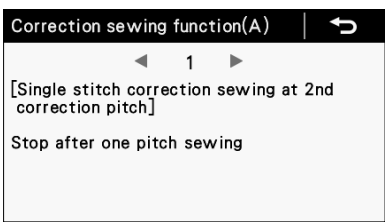
1	<p>&lt;Switching to hand switch setting mode&gt;</p> 	<p>At the menu screen, select "Hand switch setting" to switch to hand switch setting mode.</p>
2	<p>Hand switch setting</p>  <p>Hand switch A function setting</p> <p>Hand switch B function setting</p> <p>The 2nd pitch ratio</p> <p>Correction 2nd pitch ratio</p> <p>Hand switch A function setting</p>  <p>Correction sewing function</p> <p>Other function of Correction sewing</p>	<p>Select the desired menu.</p> <p>For example, to set hand switch A so that it operates as a correction sewing switch:</p> <ol style="list-style-type: none"> <li>1. Select "Hand switch A function setting".</li> <li>2. Next, select "Correction sewing function".</li> </ol>
3	<p>Correction sewing function(A)</p>  <p>[Single stitch correction sewing at 2nd correction pitch]</p> <p>Stop after one pitch sewing</p>	<p>Press the ◀ or ▶ key to select the desired setting.</p> <ul style="list-style-type: none"> <li>• Press the return key to return to the previous screen.</li> <li>• Press the menu key to return to the menu screen.</li> </ul>

### 6-10-2. 2nd correction pitch setting

Normally, correction sewing is carried out at the currently-set sewing pitch. However, when "Correction sewing at 2nd correction pitch" is set for carrying out correction sewing, then correction sewing is carried out at the pitch which is set below.

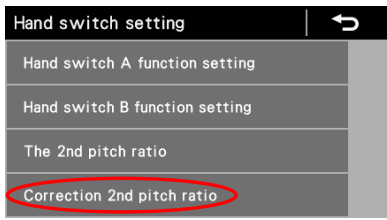
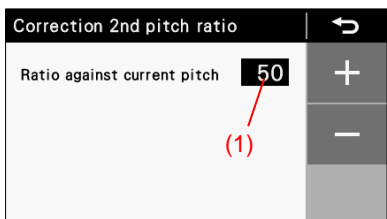
<b>1</b>	<p>&lt;Switching to correction 2nd pitch ratio screen&gt;</p> 	<p>At the hand switch setting screen, select "Correction 2nd pitch ratio".</p>
<b>2</b>		<p>Use the + or - key to set the ratio (1) with respect to the current pitch. The setting range is from 10% to 250%.</p> <ul style="list-style-type: none"> <li>• Press the return key to return to the previous screen.</li> <li>• Press the menu key to return to the menu screen.</li> </ul>

### 6-10-3. 2nd pitch setting

If "2nd pitch" has been set and the hand switch is pressed during sewing, the stitch pitch will change to the pitch set as follows.

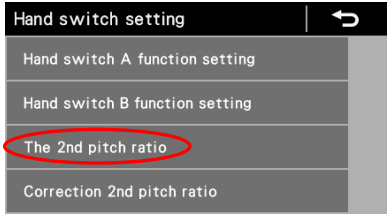
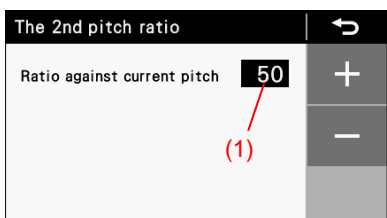
<b>1</b>	<p>&lt;Switching to 2nd pitch ratio screen&gt;</p> 	<p>At the hand switch setting screen, select "2nd pitch ratio".</p>
<b>2</b>		<p>Use the + or - key to set the ratio (1) with respect to the current pitch. The setting range is from 10% to 250%.</p> <ul style="list-style-type: none"> <li>• Press the return key to return to the previous screen.</li> <li>• Press the menu key to return to the menu screen.</li> </ul>

## 6-11. Reading and writing data using USB media

Programs and memory switch data can be copied between sewing machines by means of USB media.

### CAUTION

 Do not connect anything to the USB port other than the USB memory. If this is not observed, problems with operation may result.

**1** <Switching to USB media read/write mode>

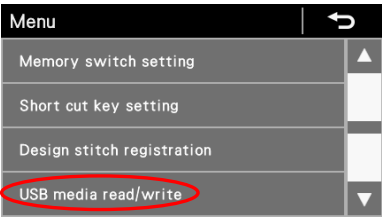

1. First connect the USB media to the sewing machine.
2. At the menu screen, select "USB media read/write" to switch to USB media read/write mode.

\* Multi card readers may not be recognized correctly.

**2** <USB media read/write mode>

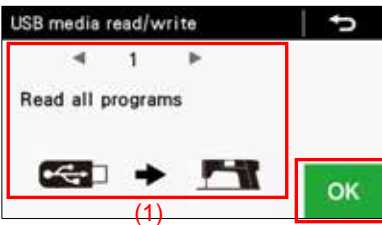

- (1) The currently-selected read/write item and illustration are displayed, so press the ◀ or ▶ key to change the read/write item.
- (2) Press the OK key to run the selected read/write item. The read/write in progress screen will be displayed.

\* If no USB media is connected at this time, the message "USB media can not be detected." will be displayed.

- Press the return key to return to the setting menu.

The read/write items that can be selected are as follows.



Code	Setting item	Read/write direction
1	Read all programs	USB media → (Panel) →Sewing machine
2	Write all programs	USB media ← (Panel) ←Sewing machine
3	Read all memory switches	USB media → (Panel) →Sewing machine
4	Write all memory switches	USB media ← (Panel) ←Sewing machine
5	Read all data	USB media → (Panel) →Sewing machine
6	Write all data	USB media ← (Panel) ←Sewing machine
7	Write production information	USB media ← (Panel) ←Sewing machine
8	Write error log	USB media ← (Panel) ←Sewing machine

Creating folders for USB media

Data type	Filename	Folder name
Program	ISMUPG.SEW	¥BROTHER¥ISM¥ISMDF**¥ (* is the value for MSW-750) (Refer to the Service Manual for details on MSW-750.)
Memory switches	ISMMSW.SEW	Same as above
Cycle programs	ISMCYC.SEW	Same as above
Program common functions	ISMCOM.SEW	Same as above
Design stitches	ISMDSW.SEW	Same as above
Hand switch	ISMHSW.SEW	Same as above
Error log	E*****.LDT M*****.LDT	¥BROTHER¥ISM¥ISMLDT¥
Production data	P*****.LDT	Same as above



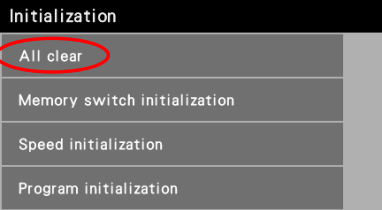
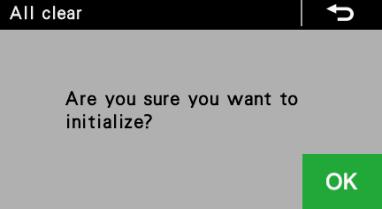

## 6-12. Resetting all settings to their defaults

If the sewing machine stops operating normally, the cause may be that an incorrect setting may have been made for the memory data by means of memory switches, for instance. In such cases, it may be possible to restore normal operation by following the steps given below to initialize the stored data.

<b>1</b>	<p>Switching to initialization mode and initialization method</p>  <p>1. While pressing the home key, turn on the power to switch to the initialization menu screen.</p>  <p>2. At the initialization menu screen, you can select the items to be initialized.</p>  <p>3. When you select an item to be initialized, the "Are you sure you want to initialize?" confirmation screen will be displayed. Press OK to carry out the initialization. When initialization is complete, the display will return to the initialization menu screen.</p>
<b>2</b>	<p>To exit from the initialization menu screen</p>  <p>At the initialization menu screen, press the home key to close the initialization menu and switch to the home screen.</p>

## 7. SEWING

### CAUTION

-  Attach all safety devices before using the sewing machine. If the machine is used without these devices attached, injury may result.
-  Turn off the power switch at the following times.  
The machine may operate if the treadle is depressed by mistake, which could result in injury.
  - When threading the needle
  - When replacing the bobbin and needle
  - When not using the machine and when leaving the machine unattended
-  Do not touch any of the moving parts or press any objects against the machine while sewing, as this may result in personal injury or damage to the machine.
-  Secure the table so that it will not move when tilting back the machine head. If the table moves, it may crush your feet or cause other injuries.
-  Use both hands to hold the machine head when tilting it back or returning it to its original position. If only one hand is used, the weight of the machine head may cause your hand to slip, and your hand may get caught.

### 7-1. Sewing

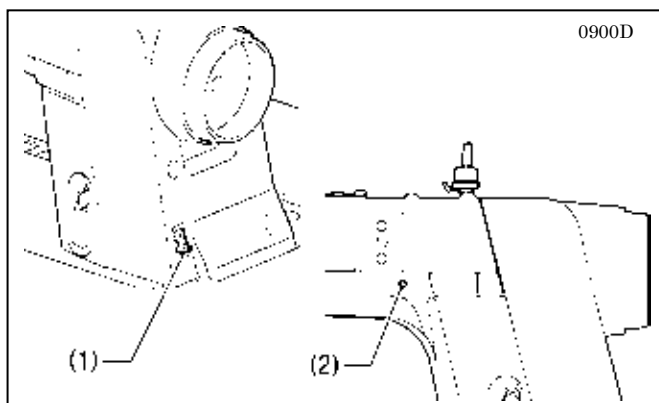

1. Press the power ON switch (1).  
The power indicator (2) will illuminate.
2. Carry out the programming which is necessary for sewing.  
(Refer to "Using the operation panel".)
3. Depress the treadle to start sewing.

### 7-2. Using the thread wiper

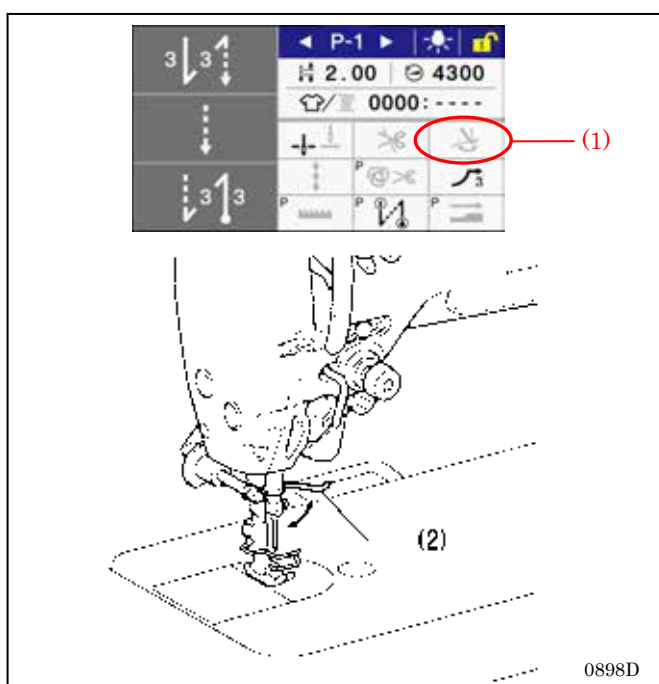

1. Press the thread wiper key (1) so that it illuminates.
2. The thread wiper (2) will operate after the thread is trimmed.

**Screens where sewing is possible**

If the treadle is depressed while any of the following screens are displayed, the sewing machine will operate. Be careful not to depress the treadle by mistake.

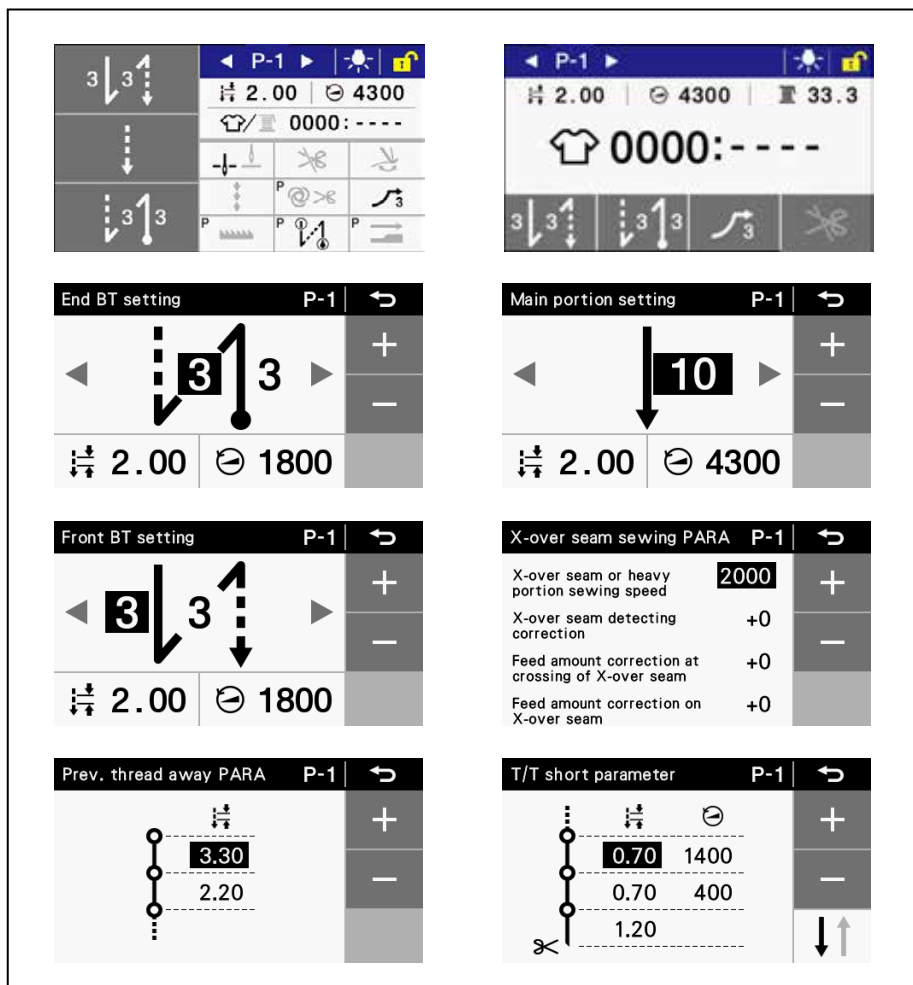

**7-3. Backtacking**

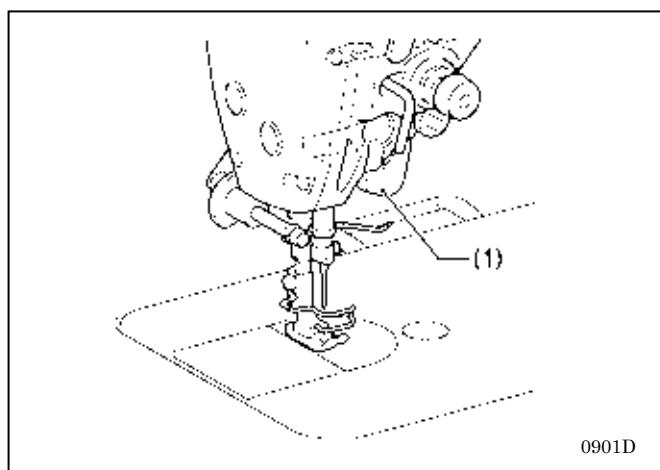

When hand switch B (1) is pressed during sewing, the feed direction will be reversed. When it is released, the feed direction will return to normal.

\* Hand switch B (1) can be set to carry out various different operations. (Refer to "6-10. Hand switches".)



## 7-4. Sewing condensed stitches

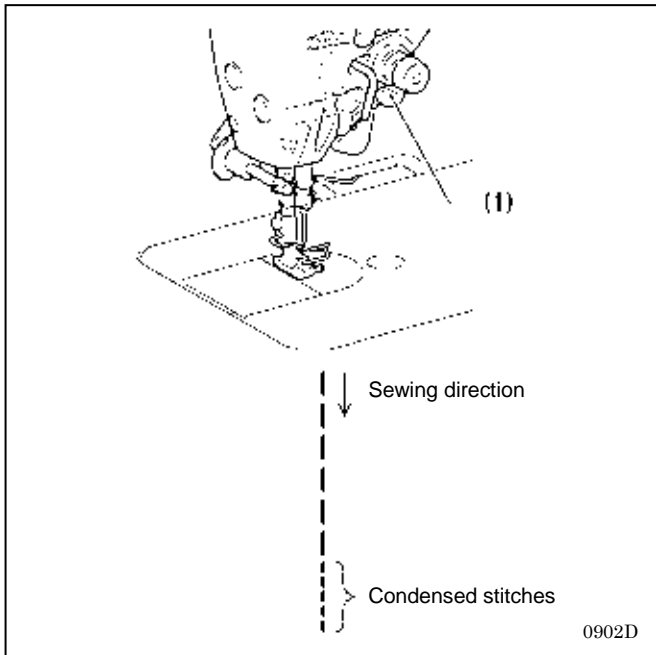

- If you press hand switch A (1) while sewing is in progress, you can sew stitches (forward direction) with small stitch lengths.
  - The stitch pitch can be changed to between the main stitch pitch and the main reverse stitch pitch depending on how far it is pushed in.
- \* Hand switch A (1) can be set to carry out various different operations.  
(Refer to "6-10. Hand switches".)

# 8. NEW FUNCTIONS

## 8-1. Best PFM mode (short trailing length/bird's nest reduction mode)

This mode reduces the occurrence of bird's nests at the sewing start, and shortens the length of thread trailing out from the material at the sewing end.

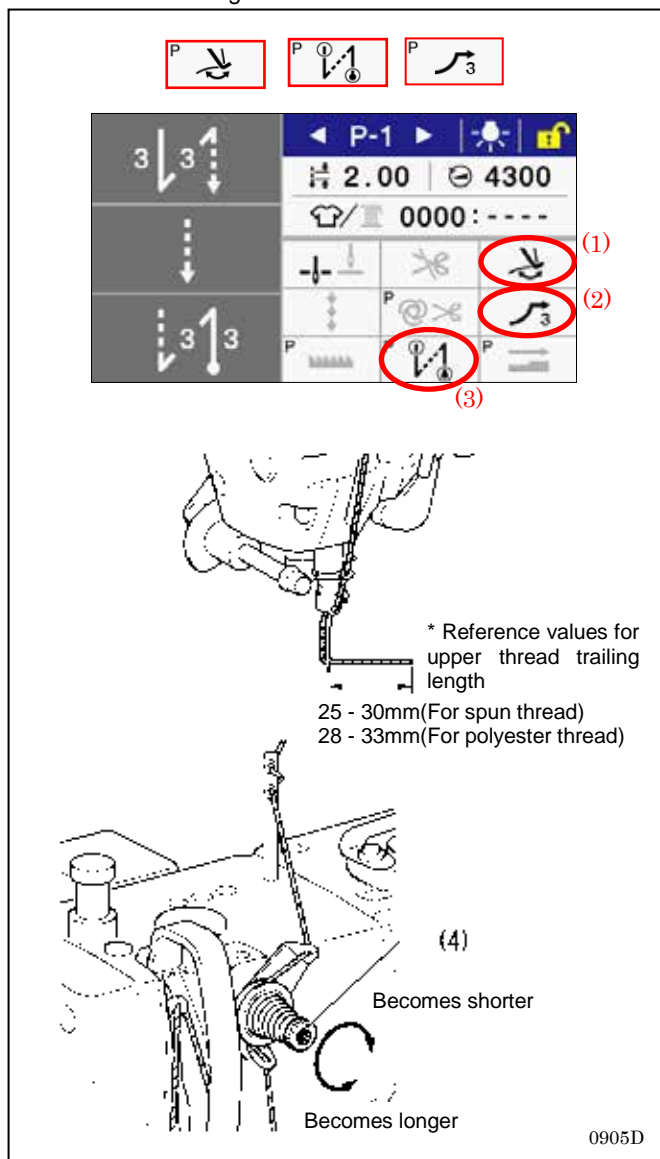

### <Setting method>

1. Press the thread wiper key (1), slow start key (2) and best PFM mode key (3) so that the icons shown in the illustration illuminate. (Refer to "5-5-8. Best PFM mode".)
2. Adjust the tension for the pre-tension (4) so that the upper thread trailing length is 25 to 30 mm (spun thread) or 28 to 33 mm (polyester thread).

## 8-2. Using X-over seam assist mode

The X-over seam sensor reduces the occurrence of tangled threads and broken needles during X-over seam sewing.

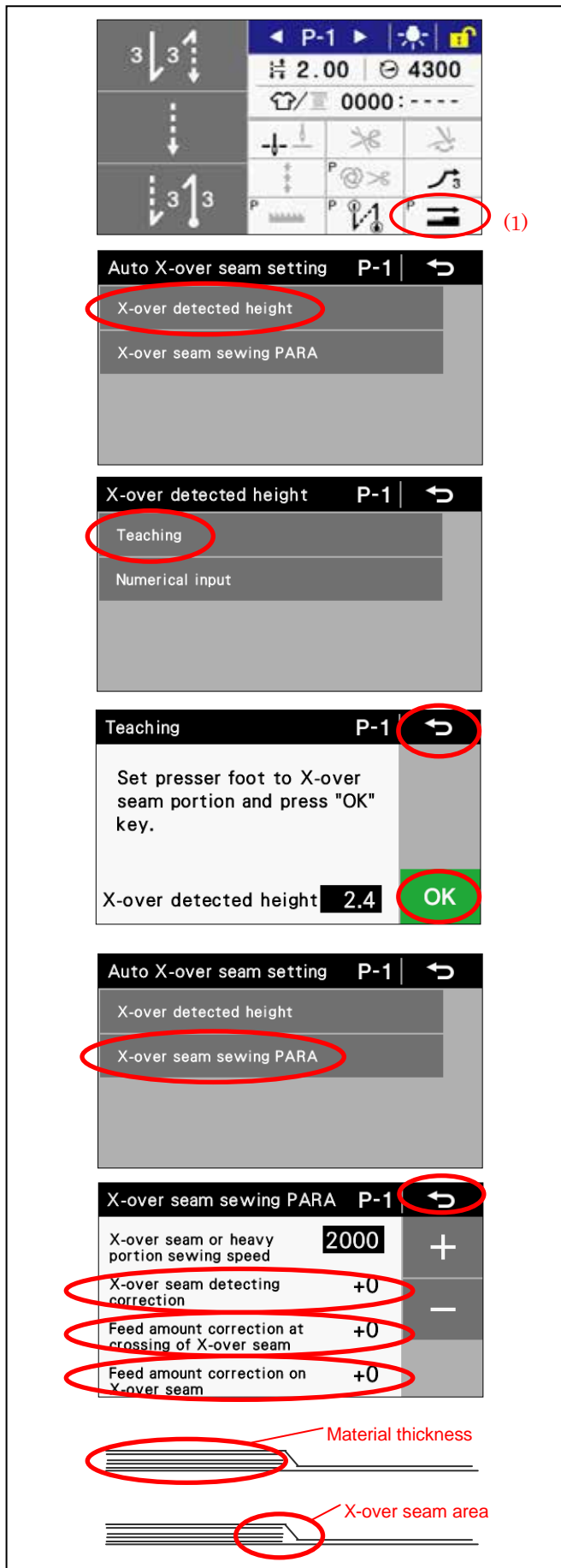

### <Setting method>

- Set the thickness of the X-over seam area.
  - 1-1. Keep pressing the X-over seam assist mode key (1), and then select "X-over detected height" → "Teaching" from the auto X-over seam setting screen.
  - 1-2. Set the presser foot onto the X-over seam area and then press the OK key.
  - 1-3. Press the return key.
    - \* Numeric value input when teaching recognition cannot be performed correctly because of the type of material
- Set the X-over seam correction value.
  - \* Only adjust if the stitch pitch is not suitable at +0.
  - 2-1. Keep pressing the X-over seam assist mode key (1), and then select "X-over seam sewing PARA" from the auto X-over seam setting screen.
  - 2-2. Select "Feed amount correction on X-over seam", and then set the correction amount. (\* The figure is a percentage, so for example, if you set it to "+1", the sewing pitch will increase by 1% of the main sewing pitch.)
  - 2-3. Select "Feed amount correction at crossing of X-over seam", and then set the correction amount. (\* The figure is a percentage, so for example, if you set it to "+1", the sewing pitch will increase by 1% of the main sewing pitch.)
  - 2-4. Press the return key.
  - 2-5. Press the X-over seam assist mode key (1) so that the icon illuminates.

### NOTE:

If the sewing pitch is incorrect and does not match the X-over seam detection timing, select "X-over seam sewing PARA" and then change the "X-over seam detecting correction" setting.

Set to positive value → Detection timing is advanced

Set to negative value → Detection timing is retarded

If a loud noise is generated, the presser foot may be bouncing. In such cases, increase the presser foot pressure, or adjust the X-over seam detection sensitivity to a negative value.

### 8-3. Using the feed dog locus

Select the feed dog locus according to the sewing application. (4 types)

1. Press the special locus key.

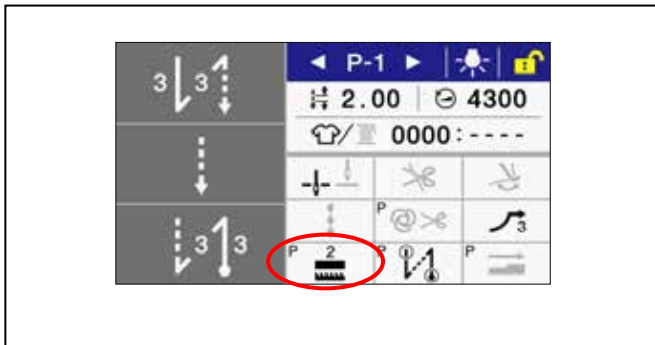

No.	Icon	Diagram of feed locus	Specifications (Sewing speed/sewing pitch)	Result
Standard			500sti/min / 4.0 400sti/min / 5.0	
1			400sti/min / 3.0 350sti/min / 4.0 200sti/min / 5.0	Improved thread tightening
2			400sti/min / 3.0 350sti/min / 4.0 200sti/min / 5.0	Fewer needle breakages Reduced thread tightening
3			200sti/min / 4.0	Improved feeding Fewer needle breakages than No. 2

Responsiveness to heavy-weight materials is improved compared to previous -3 specifications. [-3]3 specifications only]

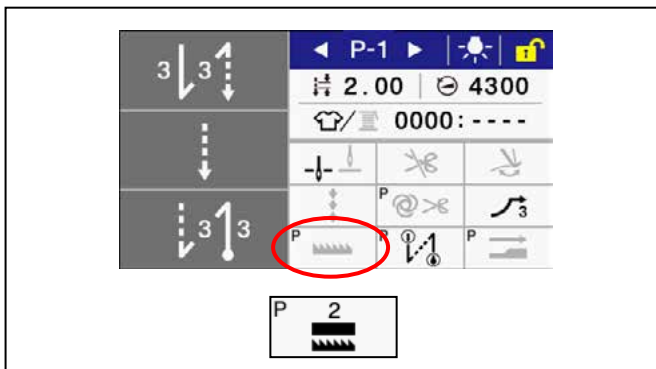

1. Use a genuine Brother rotary hook (SB6568001).
2. Replace gauge parts as necessary.  
Recommended needle plate (SB5244001)  
Recommended feed dog (SB5226001)
3. If necessary, replace the presser bar, presser spring, needle bar and main tension spring to those for -5 specifications.
4. Press the special locus key, and then select No. 2.

**NOTE:**

The sewing speed will be subjected to the following limits (sewing speed/sewing pitch).

- 400sti/min / 3.0
- 350sti/min / 4.0
- 200sti/min / 5.0

### 8-4. Example of using hand switch settings

Functions can be easily assigned to the hand switches.

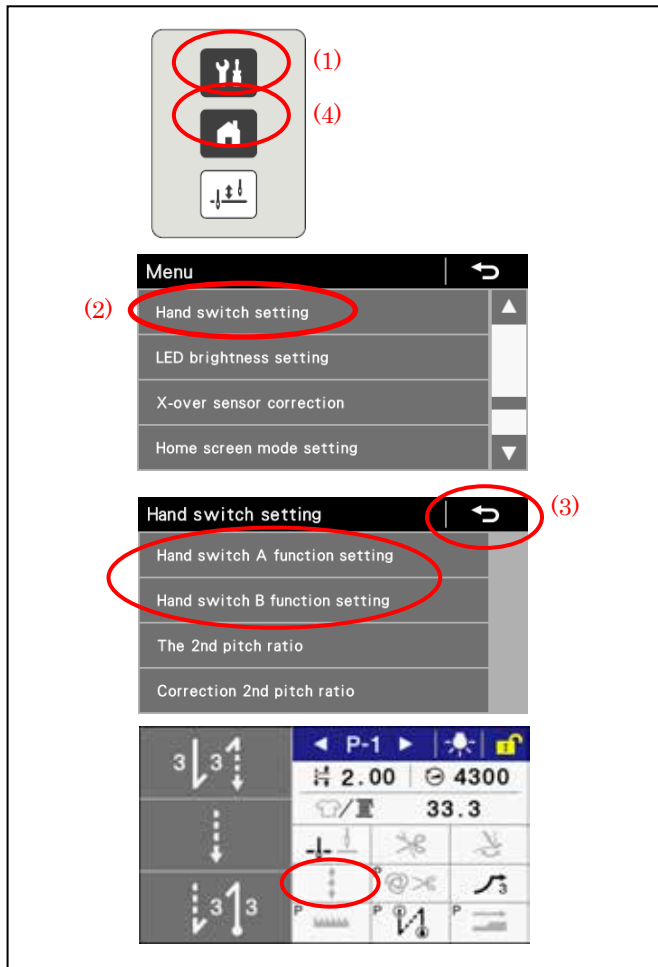

1. Press the menu key (1).
2. Press the "Hand switch setting" key (2).
3. Press the "Hand switch A function setting" key or the "Hand switch B function setting" key, and then assign the required function.
4. Press the return key (3) or the home key (4) to return to the home screen.
5. If necessary, press the correction sewing key.

#### Sewing example

No.	Hand switch A	Hand switch B	Correction sewing	Use
1	5: Second pitch	1: Reverse	OFF	<p>If the sewing pitch changes according to the material sewing direction                      Example: If set to main sewing pitch for horizontal direction and second pitch for vertical direction, use hand switch A to change the pitch in order to prevent unevenness in the stitch pitches.</p>
2	1: Correction sewing using second pitch	1: Single correction sewing	ON	<p>To match the sewing end, such as for corner sewing, set the correction 2nd pitch to 50%.                      Example: If sewing stops half a stitch short before the sewing end, press hand switch A; if it stops a single stitch short, press hand switch B.</p>
3	4: Second pitch	1: Reverse	OFF	<ul style="list-style-type: none"> <li>• If dividing sewing between condense backtack sewing and reverse backtack sewing in places where a single sewing machine is being used</li> <li>• If you would like to make the sewing pitch narrower to increase sewing strength in some sections</li> </ul> <p>Example: Set the second pitch to condense sewing pitch (around 0.7), and then press hand switch A at the condense sewing places, and press hand switch B at the reverse backtack sewing places.</p>
4	10: Presser foot lifter (switching)	1: Reverse	OFF	<p>If you would like to use a hand switch to operate the presser foot lifter                      (The optional solenoid presser foot lifter set is required.)</p>

\* Refer to "6-10. Hand switches" for other settings.

# 9. THREAD TENSION

## 9-1. Adjusting the thread tension

### CAUTION



Turn off the power switch before removing or inserting the bobbin case.  
The machine may operate if the treadle is depressed by mistake, which could result in injury.

Good even stitches



Increase the upper thread tension.  
Decrease the lower thread tension.



Decrease the upper thread tension.  
Increase the lower thread tension.

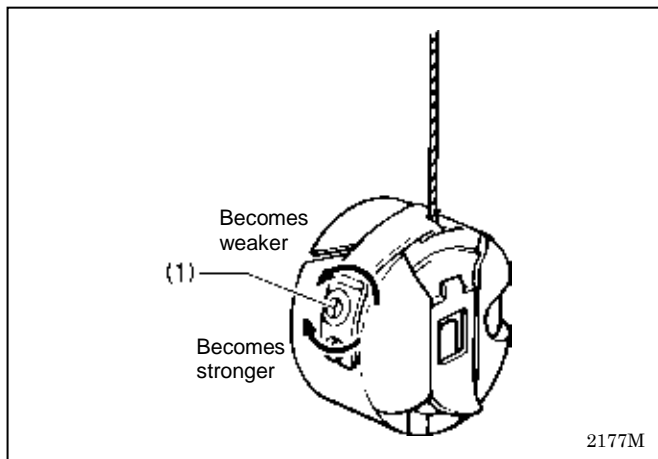

#### <Lower thread tension>

Adjust by turning the adjustment screw (1) until the bobbin case drops gently by its own weight while the thread end coming out of the bobbin case is held.

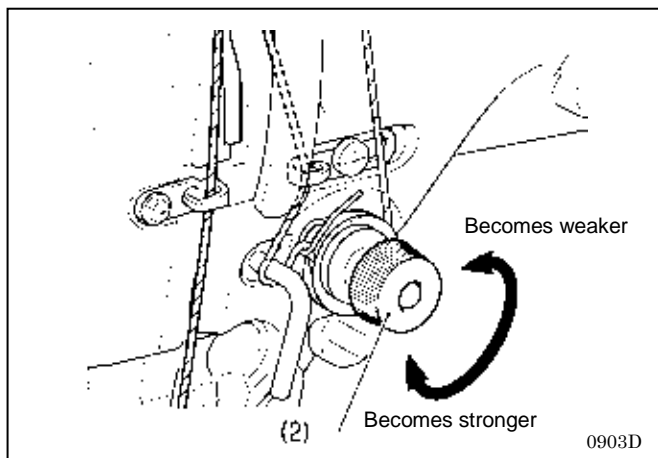

#### <Upper thread tension>

After the lower thread tension has been adjusted, adjust the upper thread tension so that a good, even stitch is obtained.

1. Lower the presser foot.
2. Adjust by turning the tension nut (2).

## 9-2. Adjusting the presser foot pressure

Good even stitches

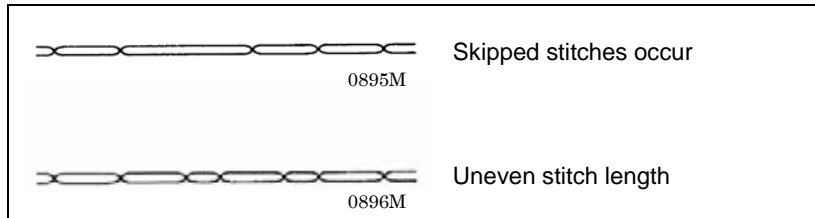
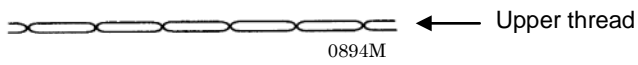

Increase the pressure

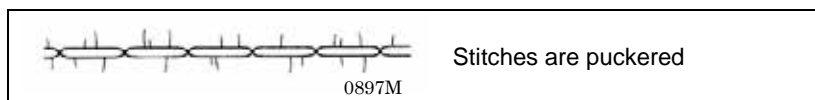

Decrease the pressure.

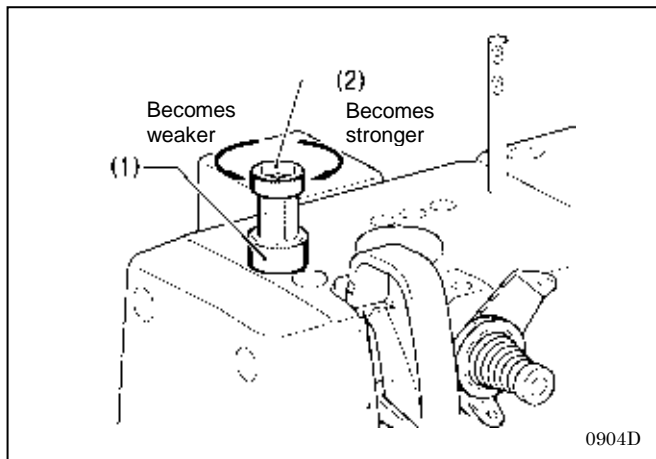

The presser foot pressure should be as weak as possible, but strong enough so that the material does not slip.

1. Loosen the adjusting nut (1).
2. Turn the presser adjusting screw (2) to adjust the presser foot pressure.
3. Tighten the adjusting nut (1).

## 9-3. Adjusting the trailing length after thread trimming

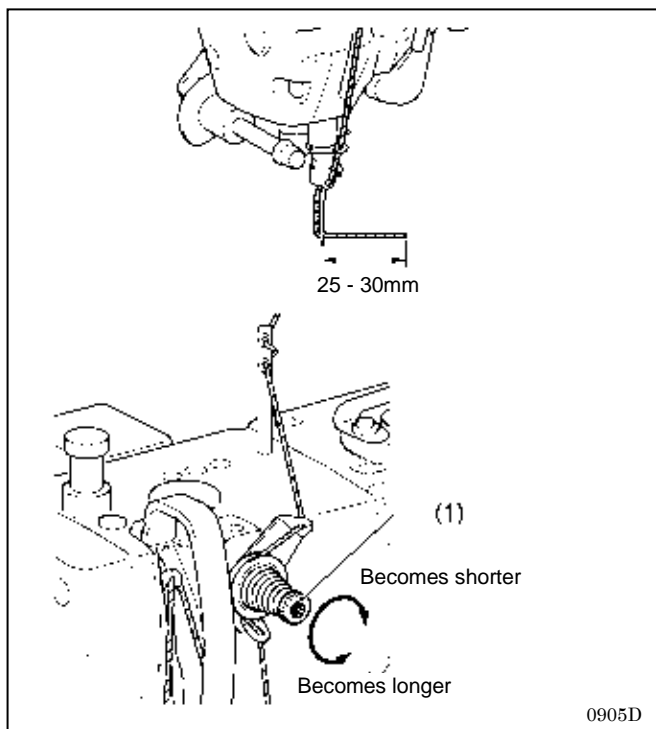

- At the time of thread trimming, the thread tension is loosened and tension is applied by the pretension (1) only.
- The standard upper thread trailing length is 25 to 30 mm.
- If the tension of the pretension (1) is increased, the lengths of the threads trailing from the needle tips will be reduced; if the tension is reduced, the lengths will be increased.

Adjust by turning the pretension (1).

## 9-4. Adjusting the thread take-up amount (-[] specifications)

### CAUTION



Turn off the power switch before carrying out these operations.  
The machine may operate if the treadle is depressed by mistake, which could result in injury.

**NOTE:** Do not use this function with models that are not -[] specifications.

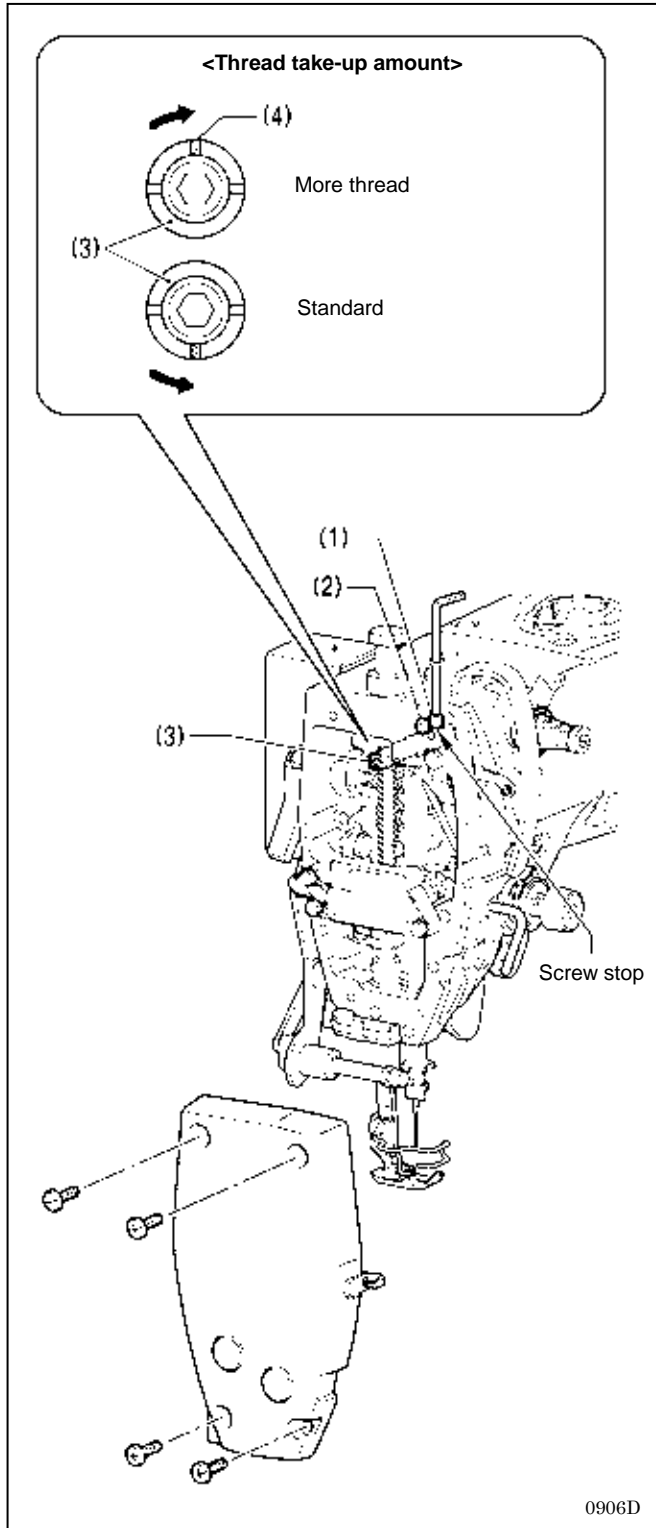

When sewing heavy materials, the thread tension can be adjusted more easily if the thread take-up amount is set to a larger amount.

1. Remove the face plate.
2. Use a hexagonal wrench to loosen the set screws (1) and (2) by approximately two turns.
3. Adjust the thread take-up amount.

#### <To increase the thread take-up amount>

Turn the thread take-up support shaft (3) clockwise so that the groove (4) is facing straight upward.

#### <To return the thread take-up amount to the standard setting>

Turn the thread take-up support shaft (3) counterclockwise so that the groove (4) is facing straight downward.

4. With the thread take-up support shaft (3) pushed in as far as it will go, first tighten the set screw (1) until it touches the screw stop on the thread take-up support shaft (3).
5. After this, tighten the set screw (2).
6. Install the face plate.

0906D



# 10. CLEANING

## CAUTION



Turn off the power switch before carrying out these operations.  
The machine may operate if the treadle is depressed by mistake, which could result in injury.



Be sure to wear protective goggles and gloves when handling the grease so that it does not get into your eyes or onto your skin. Otherwise inflammation can result.  
Furthermore, do not drink the oil or eat the grease under any circumstances. Diarrhea or vomiting may result.  
Keep the oil out of the reach of children.



Secure the table so that it will not move when tilting back the machine head.  
If the table moves, it may crush your feet or cause other injuries.



Use both hands to hold the machine head when tilting it back or returning it to its original position.  
If only one hand is used, the weight of the machine head may cause your hand to slip, and your hand may get caught.

### 10-1. Daily cleaning procedures

The following cleaning operations should be carried out each day in order to maintain the performance of this machine and to ensure a long service life. Furthermore, if the sewing machine has not been used for a long period of time, carry out the following cleaning procedures before using it again.

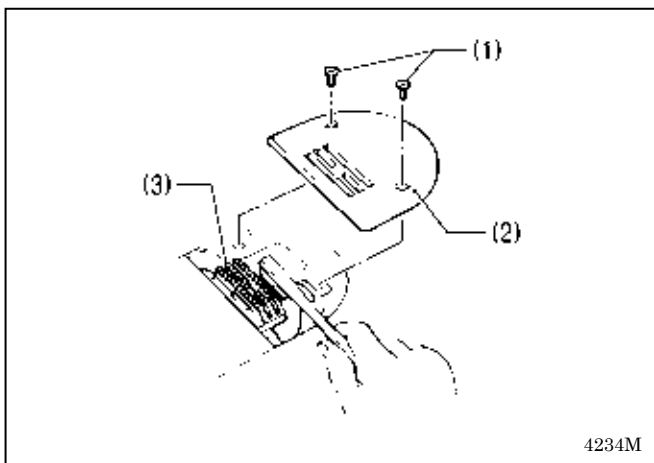

#### 1. Cleaning

1. Raise the presser foot.
2. Remove the two screws (1), and then remove the needle plate (2).
3. Use a soft wire brush to clean any dust from the feed dog (3).
4. Install the needle plate (2) with the two screws (1).

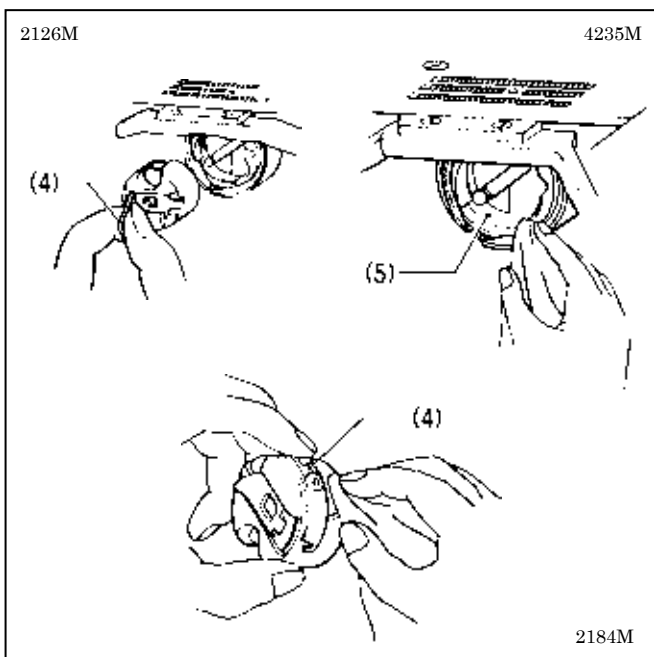

5. Tilt back the machine head.
6. Remove the bobbin case (4).
7. Wipe off any dust from the rotary hook (5) with a soft cloth, and check that there is no damage to the rotary hook (5).
8. Remove the bobbin from the bobbin case (4) and clean the bobbin case (4) with a cloth.
9. Insert the bobbin into the bobbin case (4), and then place the bobbin case (4) back into the machine.

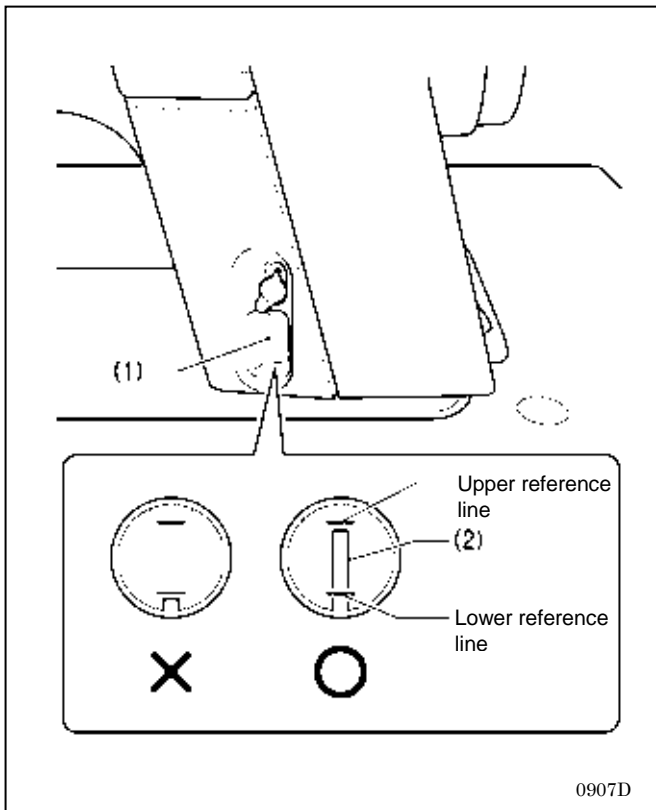

## 2. Lubrication

### Oil tank oil quantity

Check the oil gauge window (1), and add more oil if the oil gauge (2) is below the lower reference line. (Refer to "3-3. Lubrication".)

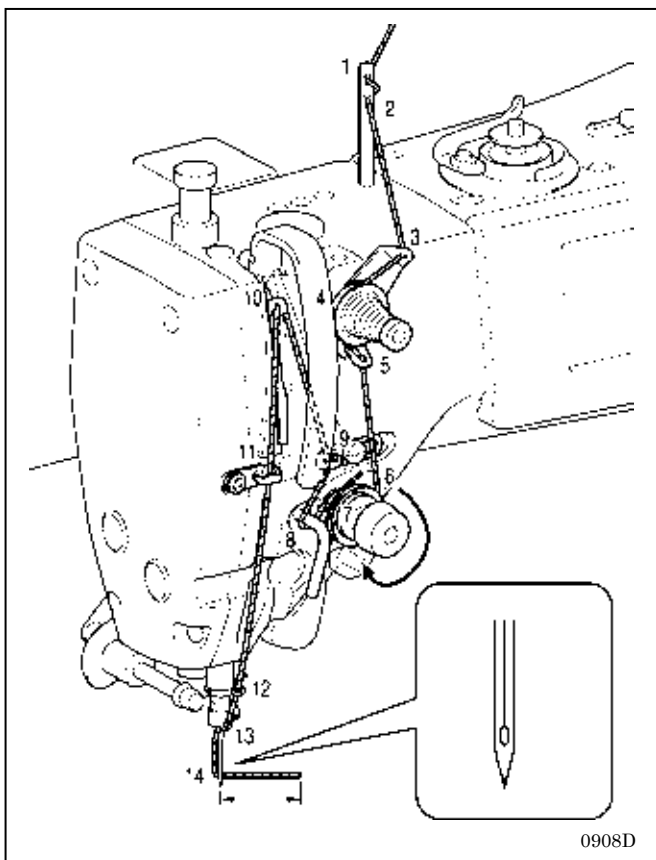

## 3. Checking

1. Replace the needle if it is bent or if the tip is broken.
2. Check that the upper threads have been threaded correctly. (Refer to "4-5. Threading the upper thread".)
3. Carry out a test sewing.

# 11. ADJUSTING THE ROTARY HOOK LUBRICATION AMOUNT

## CAUTION



Be careful not to touch your fingers or the lubrication amount check sheet against moving parts such as the rotary hook or the feed mechanism when checking the amount of oil supplied to the rotary hook. If care is not taken, injury may result.

Use the following procedure to check the amount of oil being supplied to the rotary hook when replacing the rotary hook or when changing the sewing speed.

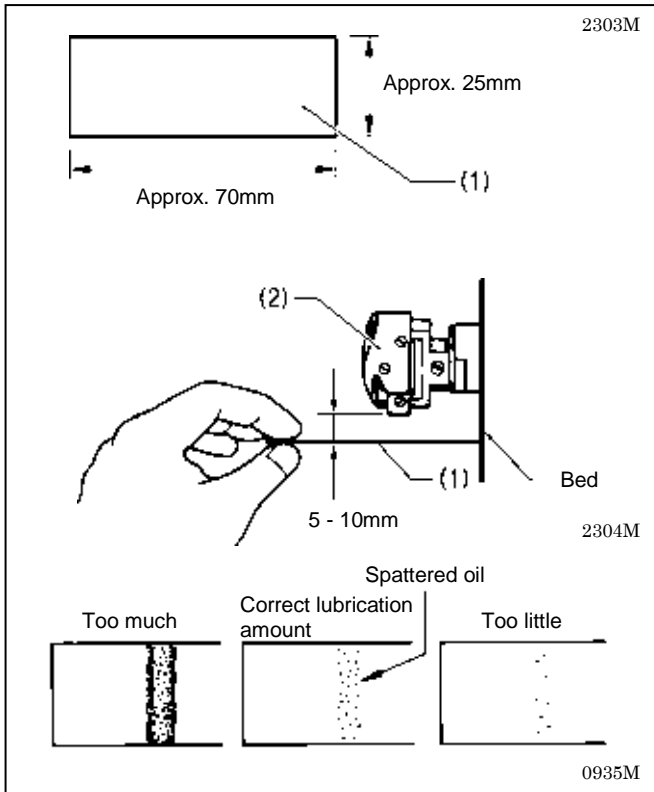

### <Checking the lubrication amount>

1. Remove the thread from all points from the thread take-up lever to the needle.
2. Use the lifting lever to lift the presser foot.
3. Run the machine at the normal sewing speed for approximately 10 minutes without sewing any material (following the same start/stop pattern as when actually sewing).
4. Place the lubrication amount check sheet (1) to the left of the rotary hook (2) and hold it there. Then run the sewing machine at the normal sewing speed for 10 seconds. (Any type of paper can be used as the lubrication amount check sheet (1).)
5. Check the amount of oil which has spattered onto the sheet.

If adjustment is necessary, carry out the following operations in "Adjusting the lubrication amount".

### NOTE:

If the lubrication amount does not match the correct amount shown in the illustration at left (if the amount of spattered oil is too much or none at all), turn the adjusting screw (3) clockwise to fully tighten it, turn it back counterclockwise by 3 1/2 turns, and then carry out the following adjustment.

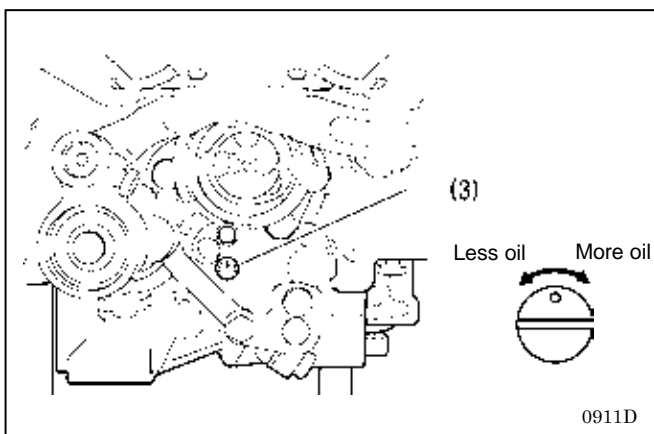







### <Adjusting the lubrication amount>

1. Tilt back the machine head.
2. Turn the adjusting screw (3) to adjust the lubrication amount.
  - If the rotary hook adjusting screw (3) is turned clockwise, the lubrication amount becomes greater.
  - If the rotary hook adjusting screw (3) is turned counterclockwise, the lubrication amount becomes smaller.
3. Check the lubrication amount again according to the procedure given in "Checking the lubrication amount" above.
  - \* Turn the rotary hook adjusting screw (3) and check the lubrication amount repeatedly until the lubrication amount is correct.
4. Check the lubrication amount again after the sewing machine has been used for approximately two hours.

# 12. STANDARD ADJUSTMENTS

## ⚠ CAUTION

-  Maintenance and inspection of the sewing machine should only be carried out by a qualified technician.
-  Ask your Brother dealer or a qualified electrician to carry out any maintenance and inspection of the electrical system.
-  If any safety devices have been removed, be absolutely sure to re-install them to their original positions and check that they operate correctly before using the machine.
-  Secure the table so that it will not move when tilting back the machine head.  
If the table moves, it may crush your feet or cause other injuries.
-  Use both hands to hold the machine head when tilting it back or returning it to its original position. If only one hand is used, the weight of the machine head may cause your hand to slip, and your hand may get caught.
-  Turn off the power switch and disconnect the power cord plug at the following times.  
The machine may operate if the treadle is depressed by mistake, which could result in injury.
  - When carrying out inspection, adjustment and maintenance
  - When replacing consumable parts such as the rotary hook and knives
-  If the power switch needs to be left on when carrying out some adjustment, make sure that you switch the sewing machine to maintenance mode.  
Pay careful attention to safety.

### 12-1. Thread tension spring

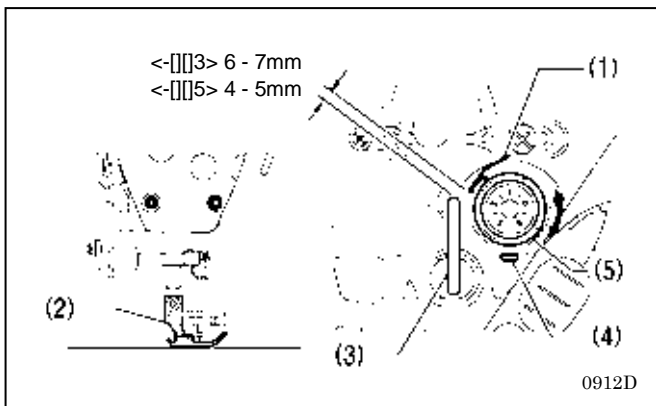

#### <Thread tension spring position>

The standard position of the thread take-up spring (1) is 6 to 7 mm (for -3 specifications) or 4 to 5 mm (for -5 specifications) above the surface of the arm thread guide (3) when the presser foot (2) is lowered.

1. Lower the presser foot (2).
2. Loosen the set screw (4).
3. Turn the thread tension bracket (5) to adjust the spring position.
4. Securely tighten the set screw (4).

\* If the lifting lever or other method has been used to raise the presser foot when adjusting the thread take-up spring, the movement amount of the thread take-up spring will be limited by the thread take-up spring stopper.

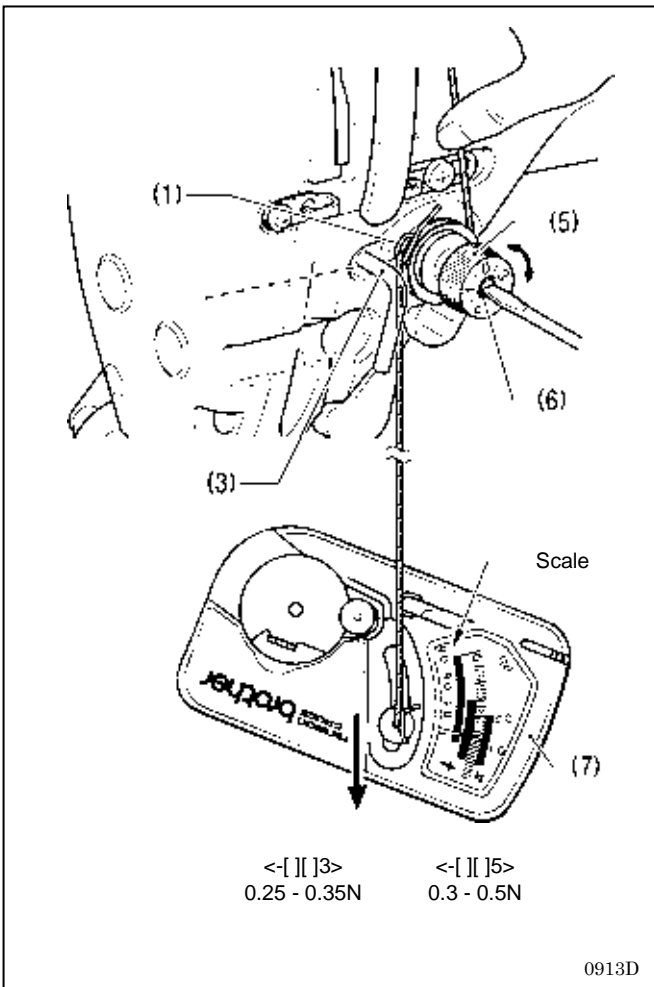

**<Thread take-up spring tension>**

The standard tension of the thread take-up spring (1) varies in accordance with the machine specifications as shown in the table.

<[ I ]3 specifications	0.25 - 0.35N
<[ I ]5 specifications	0.30 - 0.5N

1. Press the upper thread slightly above the thread tension bracket (5) with a finger to stop the thread spooling out.
2. Pull the upper thread downward so that the thread take-up spring (1) is extended to the same height as the base of the arm thread guide (3), and then measure the tension of the thread take-up spring (1).
3. Insert the tip of a screwdriver into the groove in the thread tension stud (6) and turn it to adjust the tension of the thread tension spring (1).

**NOTE:** If using a tension gauge (7) (part code: 183922-101) to measure the tension, take the upper thread reading from the scale [at the red line side].

\* Do not adjust the tension of the thread take-up spring if the presser foot has been raised by the lifting lever, or if the thread trimmer solenoid is ON.

**12-2. Arm thread guide R**

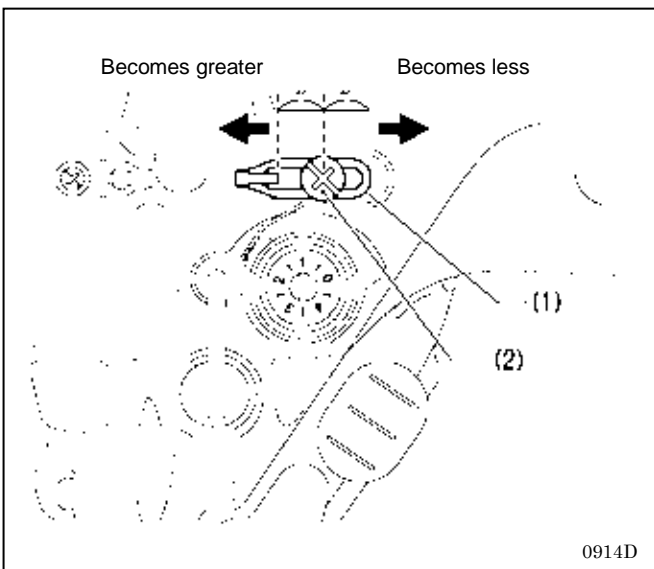

The standard position of arm thread guide R (1) is the position where the screw (2) is in the center of the adjustable range for arm thread guide R (1).

\* To adjust the position, loosen the screw (2) and then move arm thread guide R (1).

- When sewing heavy-weight material, move arm thread guide R (1) to the left. (The thread take-up amount will become greater.)
- When sewing light-weight material, move arm thread guide R (1) to the right. (The thread take-up amount will become less.)

### 12-3. Presser foot height

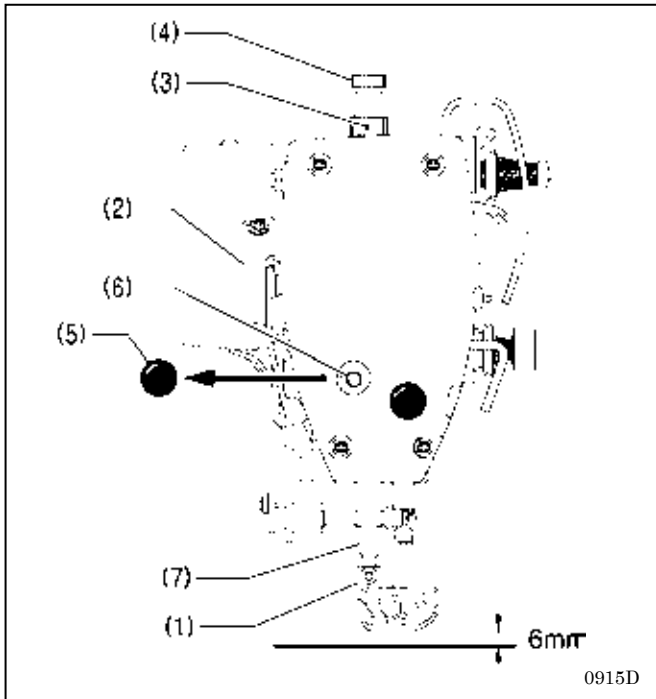

The standard height of the presser foot (1) is 6 mm when the presser foot (1) is raised by means of the lifting lever (2).

1. Loosen the nut (3), and then turn the adjustment screw (4) so that there is no pressure applied to the presser foot.
2. Raise the presser foot (1) by using the lifting lever (2).
3. Remove the rubber cap (5) from the face plate.
4. Loosen the bolt (6) and then move the presser bar (7) up or down until the presser foot (1) is at the standard height of 6 mm.
5. Tighten the bolt (6).
6. Install the rubber cap (5).
7. Adjust the presser foot pressure using the presser adjusting screw (4), and then tighten the nut (3).

### 12-4. X-over seam sensor correction

Be sure to carry out this procedure when replacing the presser foot.

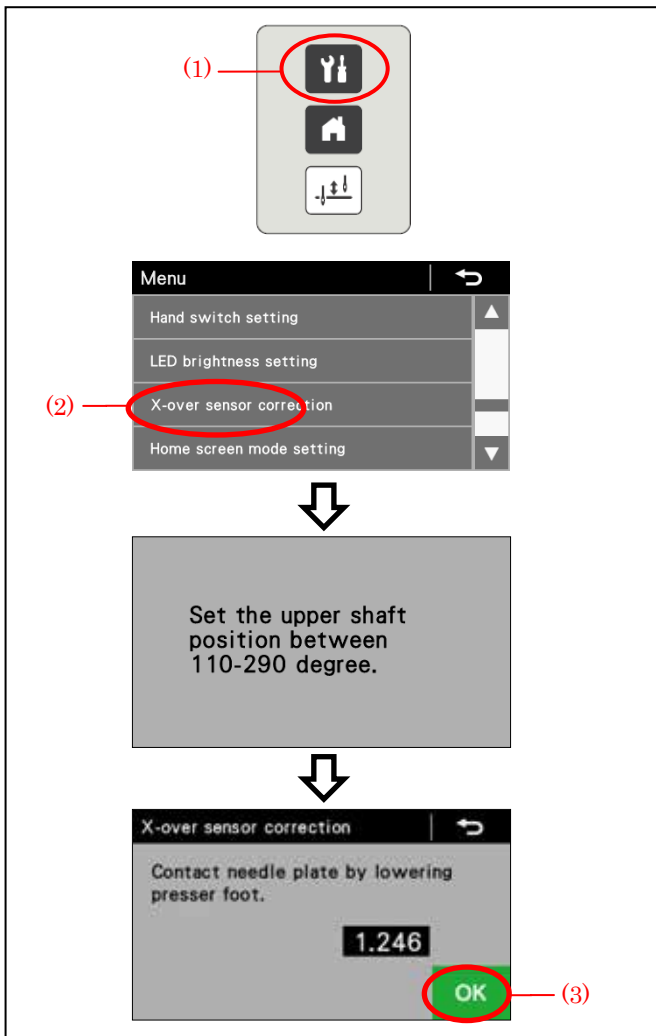

1. Turn on the power.
2. Press the menu key (1).
3. Select the "X-over seam sensor correction" key (2).
4. Turn the machine pulley to set the upper shaft position to between 110 and 290 degrees.
5. Lower the presser foot.
6. Press the OK key (3).

### 12-5. Adjusting the feed dog height

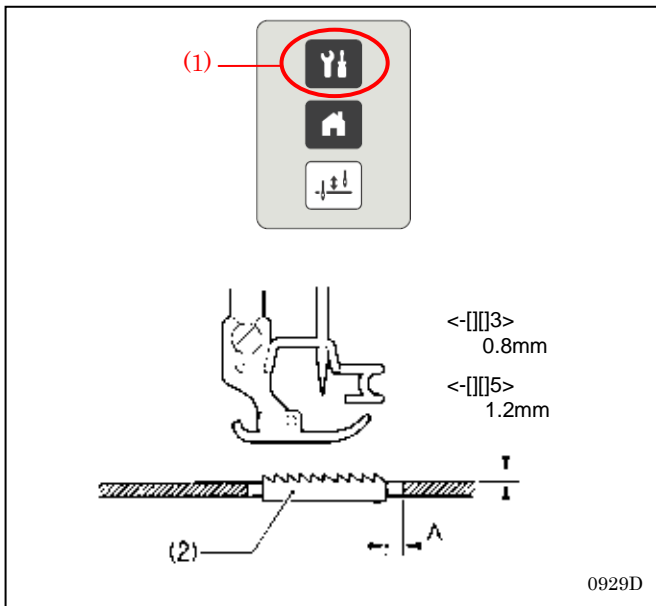

1. Turn on the power.
2. Start backtack sewing, best PFM mode, slow start, special locus and X-over seam assist will turn off.
3. Set the feed pitch to 3 mm (for -□□3 specifications) or to 5 mm (for -□□5 specifications). (Refer to "5-4-3. Main sewing settings".)
4. Press the menu key (1).
5. Check the clearance A when the feed dog (2) is at the furthest forward position.
  - 3 specifications: 0.5 mm
  - 5 specifications: 3 mm

\* The standard height of the feed dog (2) when it is raised as far as possible above the surface of the needle plate is 0.8 mm (for -□□3 specifications) or 1.2 mm (for -□□5 specifications).

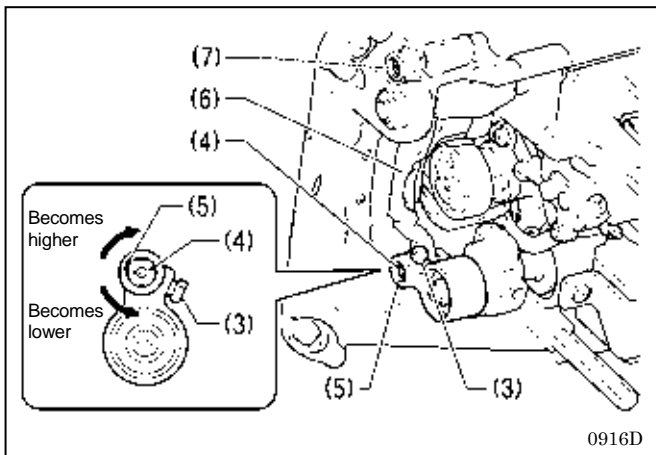

6. Turn the machine pulley to move the feed dog (2) to its highest position above the needle plate.
7. Tilt back the machine head.
8. Loosen the set screw (3).
9. Turn the feed lifting rock bracket stud (4) within a range of 90° from the reference line (5) to adjust the vertical height of the feed bar (6). (Fig. A)
10. Tighten the set screw (3).

\* If you are worried about the angle of the feed dog (2), turn the shaft (7) while carrying out the above adjustment. (Fig. (B)) (Refer to "12-6. Adjusting the feed dog angle" on the nextpage for details of this operation.)

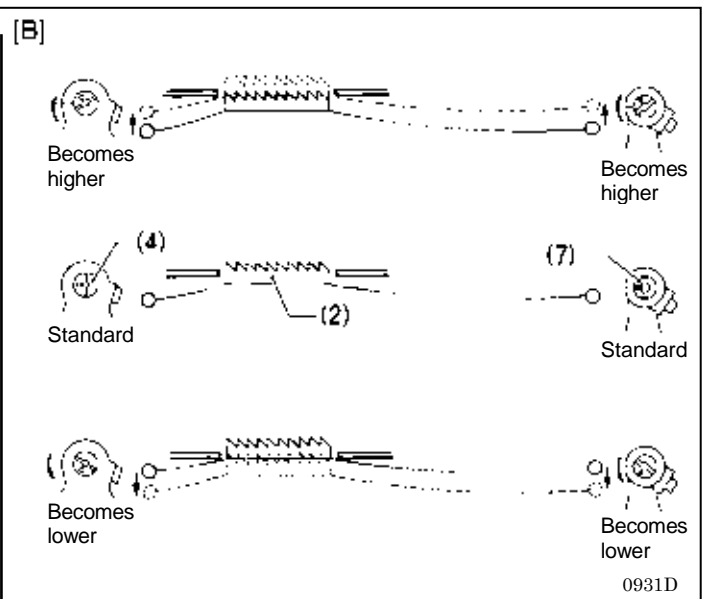
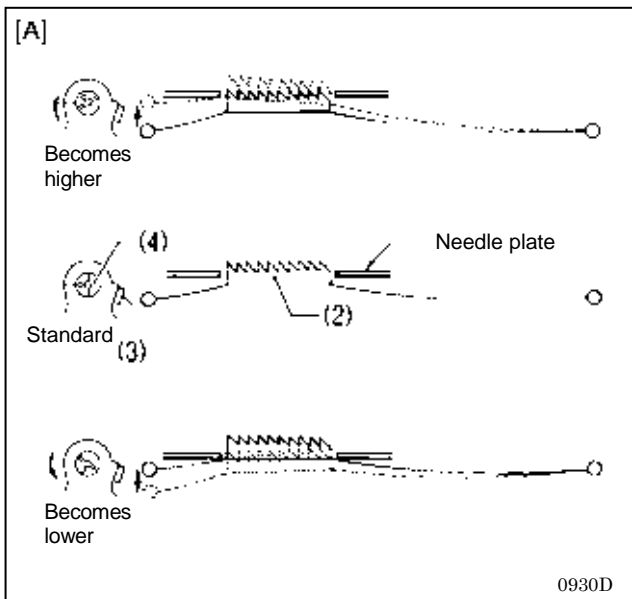

## 12-6. Adjusting the feed dog angle

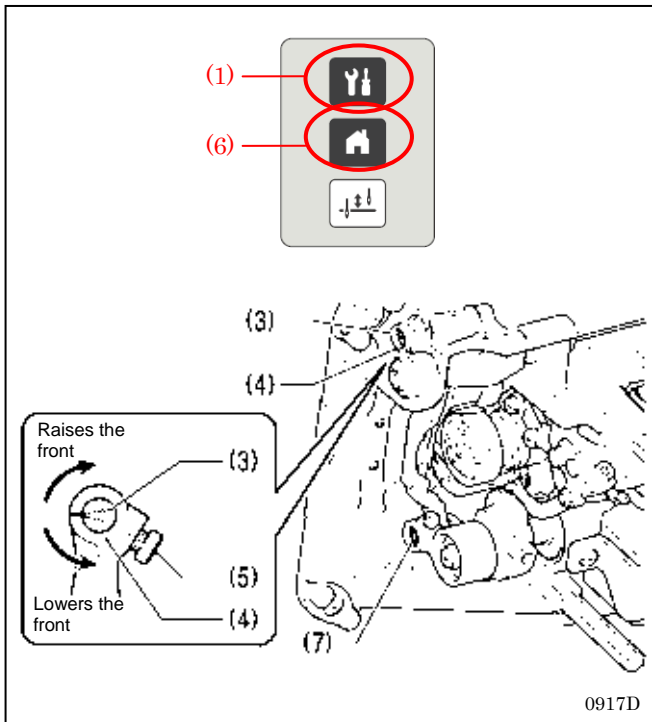

1. Turn on the power.
2. Start backtack sewing, best PFM mode, slow start, special locus and X-over seam assist will turn off.
3. Set the feed pitch to 3 mm (for -[ ]3 specifications) or to 5 mm (for -[ ]5 specifications). (Refer to "5-4-3. Main sewing settings".)
4. Press the menu key (1).

\* The standard angle for the feed dog (2) when it is lowered until its top is flush with the top of the needle plate is for the O mark (or the V groove) in the feed bar shaft (3) to be aligned with the feed rocker bracket arm (4) and for the feed dog (2) and to be parallel to the needle plate.

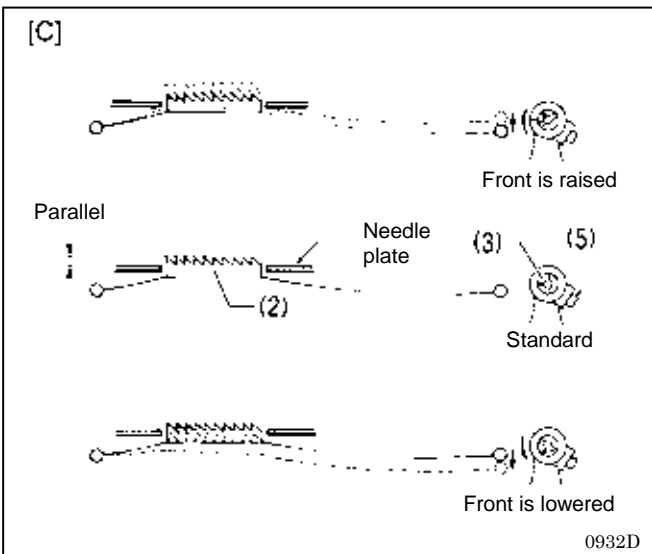

5. Turn the machine pulley to move the feed dog (2) to its highest position above the needle plate.
6. Tilt back the machine head.
7. Loosen the set screw (5).
8. Turn the feed base shaft (3) in the direction of the arrow within a range of 90° with respect to the standard position. (Figure <C>)

- In order to prevent puckering, lower the front of the feed dog (2).
- In order to prevent the material from slipping, raise the front of the feed dog (2).

9. Securely tighten the set screw (5).
10. Press the home key (6).

\* If you would like to tilt the feed dog (2) further, turn the feed lifting rock bracket stud (7) while carrying out the above adjustment. (Figure <D>) (Refer to "12-5. Adjusting the feed dog height" on the previous page for details of this operation.)

\* The height of the feed dog (2) will change after the angle has been adjusted, so it will be necessary to re-adjust the height of the feed dog (2).

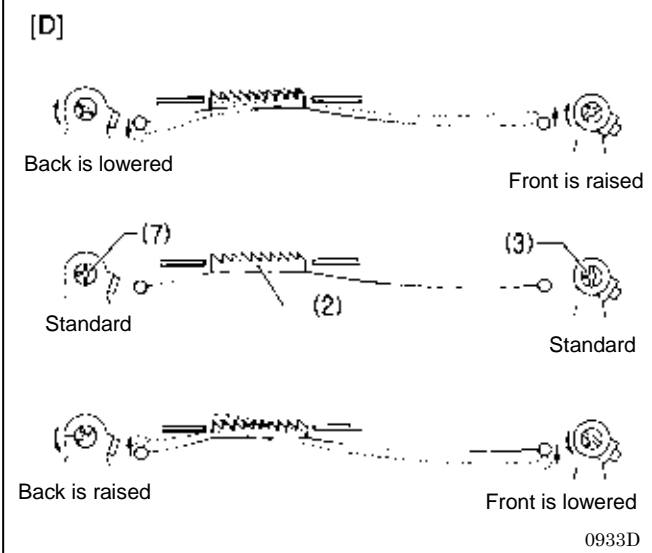



## 12-7. Adjusting the needle bar height

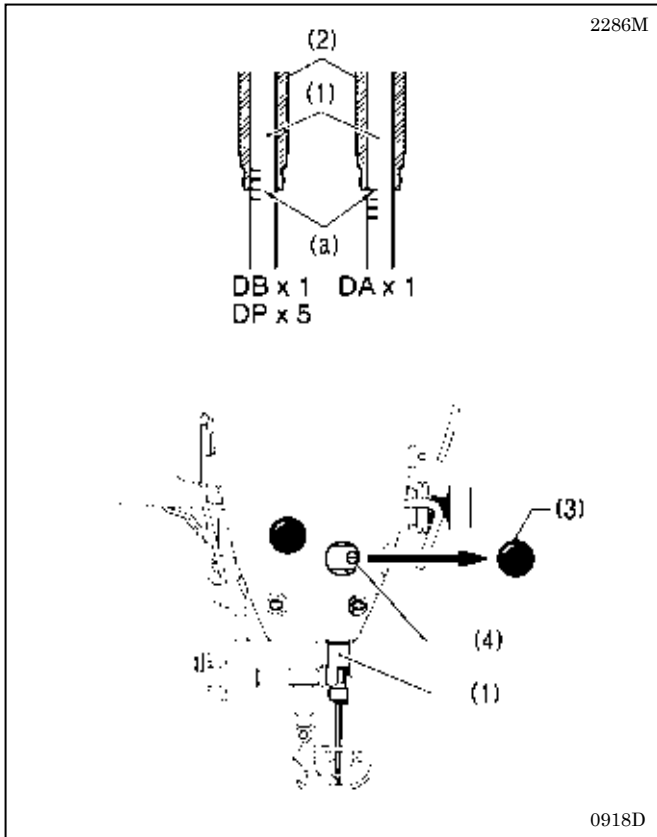

Reference line (a) on the needle bar (1) should be aligned with the lower edge of the needle bar bush (2) as shown in the illustration when the needle bar (1) is at its lowest position.

1. Turn the machine pulley to set the needle bar (1) to its lowest position.
2. Remove the rubber cap (3) from the face plate.
3. Loosen the screw (4) and move the thread wiper (1) up or down to adjust its position.
4. Securely tighten the screw (4).
5. Install the rubber cap (3).

### 12-8. Adjusting the needle and feed mechanism timing

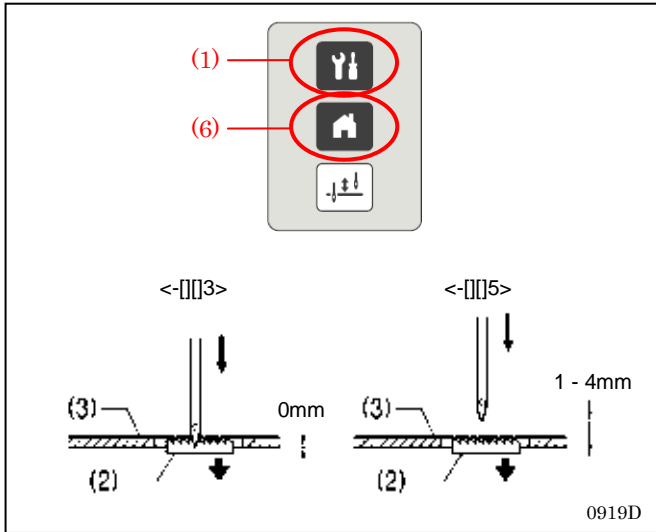

1. Turn on the power.
2. Start backtack sewing, best PFM mode, slow start, special locus and X-over seam assist will turn off.
3. Set the feed pitch to 3 mm (for -[ ]3 specifications) or to 4 mm (for -[ ]5 specifications). (Refer to "5-4-3. Main sewing settings".)
4. Press the menu key (1).
  - \* The standard position for the point of the needle is as described below when the feed dog (2) is lowered from its highest position until it is aligned with the top of the needle plate (3).

<math>\langle \text{---} \text{---} \text{---} \rangle</math> This is the position where the top of the feed dog (2) and the top of the needle plate (3) are aligned, and the point of the needle is aligned with the bottom edge of the needle plate (3).

<math>\langle \text{---} \text{---} \text{---} \rangle</math> The top of the feed dog (2) and the top of the needle plate (3) are aligned, and there is a clearance of 1 to 4 mm between the point of the needle and the top of the needle plate (3).

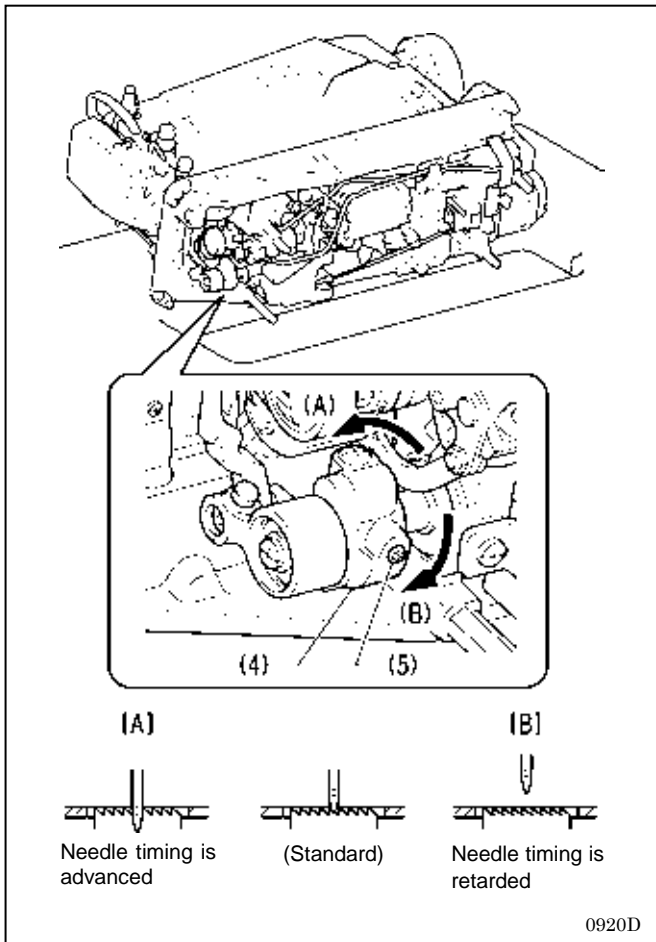

5. Tilt back the machine head.
6. Loosen the two set screws (5) of the feed lifting eccentric cam (4), and then turn the feed lifting eccentric cam (4) slightly to adjust the timing.

- To advance the needle timing, turn in the direction of <math>\langle A \rangle</math>, and to retard the needle timing, turn in the direction of <math>\langle B \rangle</math>.
- To prevent material slippage from occurring, retard the needle timing. (Fig. (B))
- To improve thread tightening, advance the needle timing. (Fig. (A))

**NOTE:** If the feed lifting eccentric cam (4) is turned too far in the direction of <math>\langle A \rangle</math>, it may cause the needle to break.

7. After adjusting, securely tighten the set screw (5).
8. Press the home key (6).

## 12-9. Needle and rotary hook timing

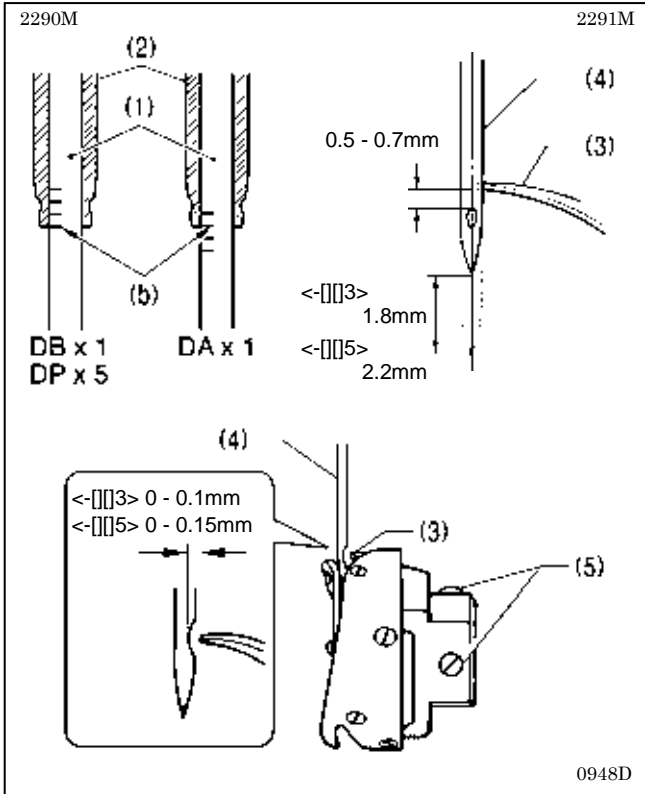

The rotary hook tip (3) should be aligned with the center of the needle (4) when the needle bar (1) moves up 1.8 mm (for -3 specifications) or 2.2 mm (for -5 specifications) from its lowest position to the position where reference line (b) is aligned with the needle bar bush (2) as shown in the illustration.

(The distance from the upper edge of the needle hole to the rotary hook tip will be 0.5 to 0.7 mm at this time.)

1. Turn the machine pulley to raise the needle bar (1) from its lowest position until reference line (b) is aligned with the lower edge of the needle bar bush (2) as shown in the illustration.
2. Loosen the three set screws (5), and then align the rotary hook tip (3) with the center of the needle (4). There should be a gap of 0 to 0.1 mm (for -3 specifications) or 0 to 0.15 mm (-5 specifications) between the rotary hook tip (3) and the needle (4) at this time.
3. Securely tighten the three set screws (5).

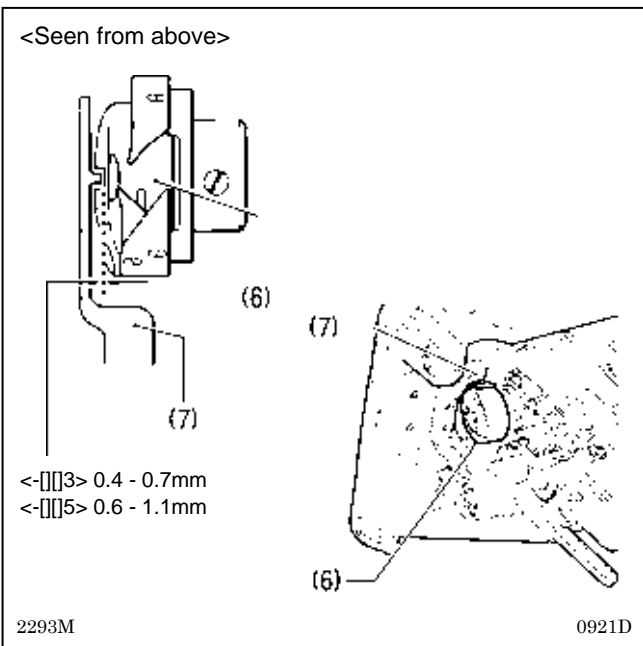

### <Checking the clearance between the rotary hook and bobbin case holder position bracket>

Check that the clearance between the rotary hook (6) and the bobbin case holder position bracket (7) is enough to allow the thread being used to pass through smoothly.

The clearance should be 0.4 to 0.7 mm (for -3 specifications) and 0.6 to 1.1 mm (for -5 specifications).

## 12-10. Adjusting the presser foot floating amount (minute lifting amount) (option)

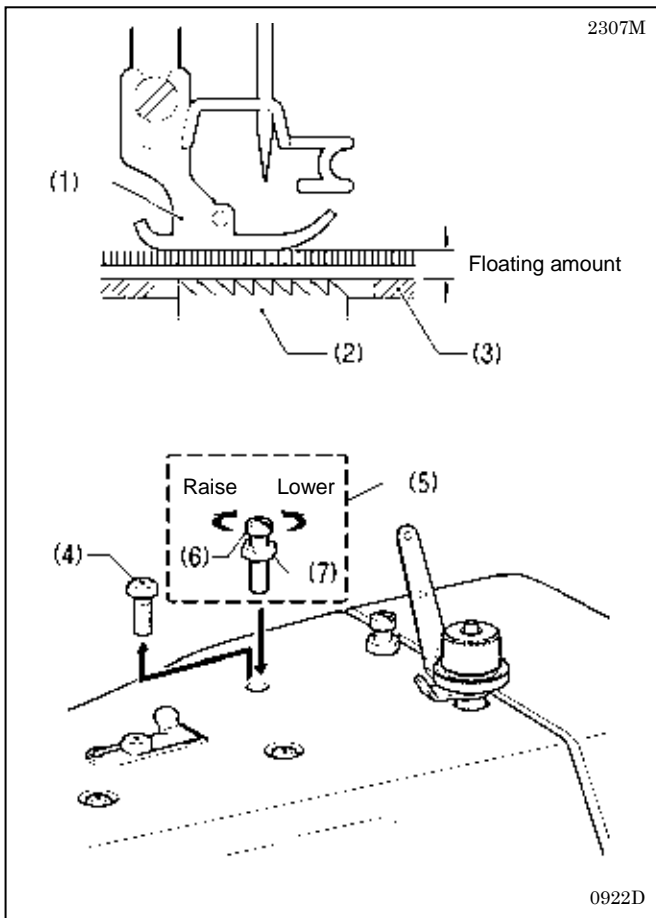

When sewing stretch materials and materials with long pile, you can make minute adjustments to the floating amount for the presser foot (1) in accordance with the material.

1. Turn the sewing machine pulley by hand to move the feed dog (2) below the needle plate (3).
2. Use the lifting lever to lower the presser foot (1).
3. Remove the screw (4), and then replace the adjustment screw set (5) (option SB6564).
4. Turn the adjusting screw (6) to adjust the floating amount.
  - To raise the presser foot (1)...Turn the adjusting screw (6) clockwise.
  - To lower the presser foot (1) ... Turn the adjusting screw (6) counterclockwise.
5. Tighten the nut (7).

\* After making the adjustment, sew a piece of material to check the floating amount.

## 12-11. Thread trimming

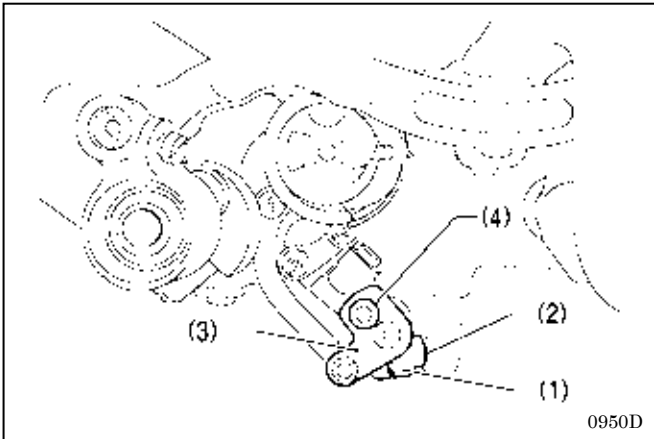

1. Turn off the power switch.
2. Remove the presser foot, needle plate and feed dog.
3. Tilt back the machine head.
4. Loosen the screw (2) of the thread trimmer lever (1) and the screw (4) of the upper knife lever (3).  
(This will allow the upper and lower knife holders and the needle bar mechanism to operate independently.)

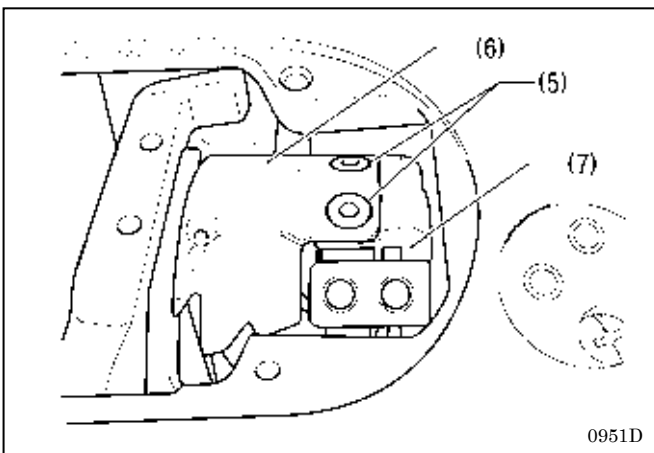

5. Install the lower knife (6) to the lower knife holder (7) with the two screws (5).

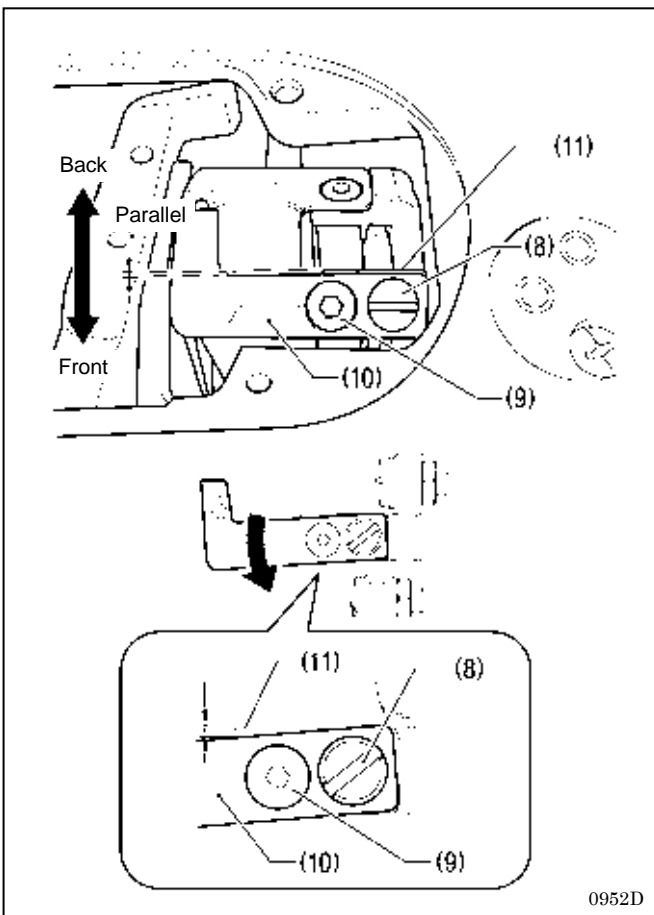

6. Install the upper knife (10) with the two screws (8) and (9).
  - \* Install the upper knife (10) so that it is almost parallel to the ridge line on the mounting surface of the upper knife holder (11).
  - \* If the upper knife (10) is tilted forward, the knife pressure will increase, and if it is tilted backward, the knife pressure will decrease.
  - \* After adjusting, operate the upper and lower knife holders by hand and check that the thread can be trimmed.
- \* If using thick thread, or if the thread is not being trimmed, adjust the tilt of the upper knife (10) forward.
- \* Tilt the upper knife (10) forward slightly (about 0.3 mm) so that the ridge line on the mounting surface of the upper knife holder (11) is slightly visible.  
(The head of the screw (9) is pan-shaped, and so the upper knife (10) can pivot on this screw when it is tilted.)

## 12. STANDARD ADJUSTMENTS

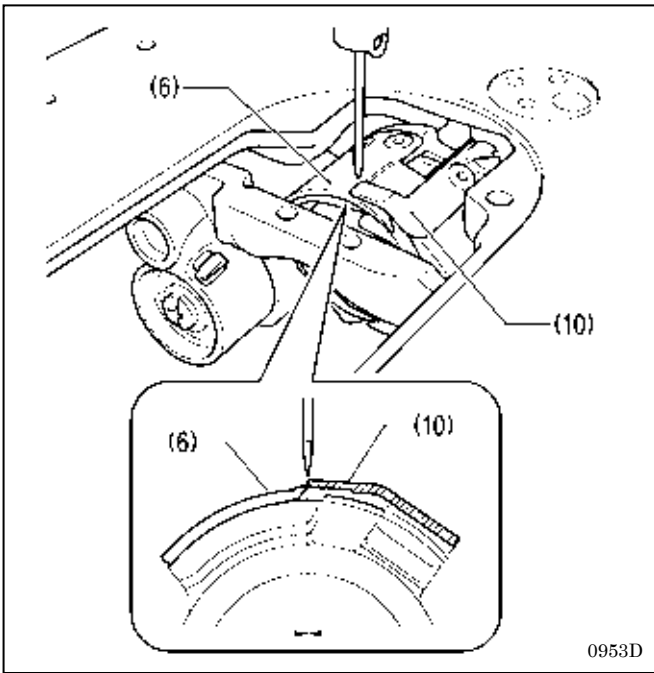

7. Adjust the positions of the upper and lower knife holders so that the upper knife (10) and the lower knife (6) mesh and the tips of both knives are aligned at the center of the needle.

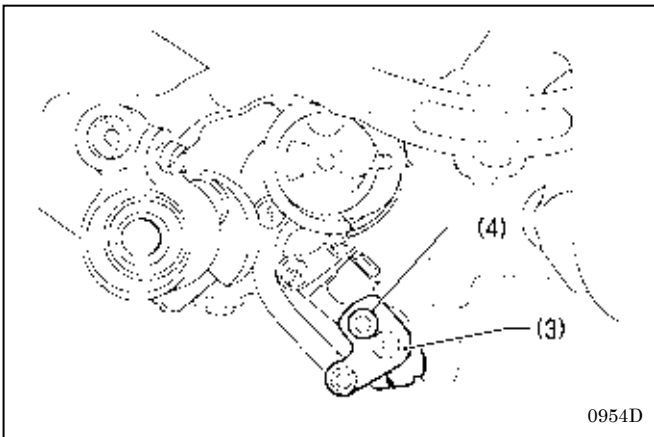

8. Tighten the screw (4) of the upper knife lever (3) to secure the upper knife (10) in place.

\* Tighten the screw (4) gently but securely at this time so that the upper knife lever (3) does not shift its position. As a guide, the screw (4) should be positioned in the center of the slot in the upper knife lever (3).

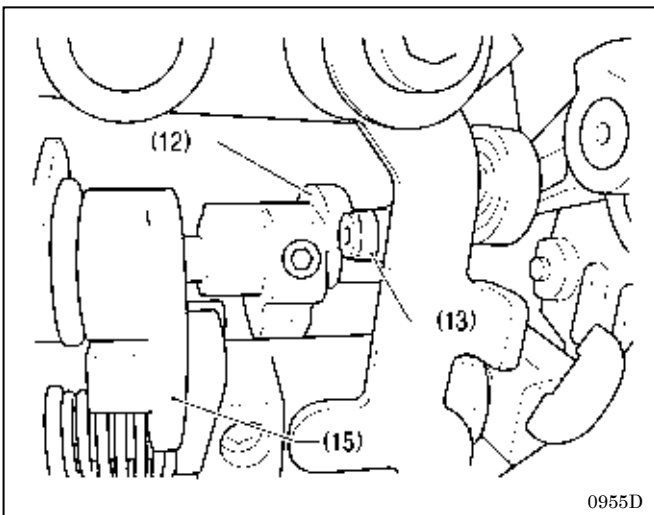

9. Turn the machine pulley while the thread trimmer solenoid is still turned on so that the thread trimmer cam (12) moves the thread trimmer cam roller (13) to its maximum displacement position.

\* Make sure that the thread trimmer solenoid does not turn off and does not return during this step.

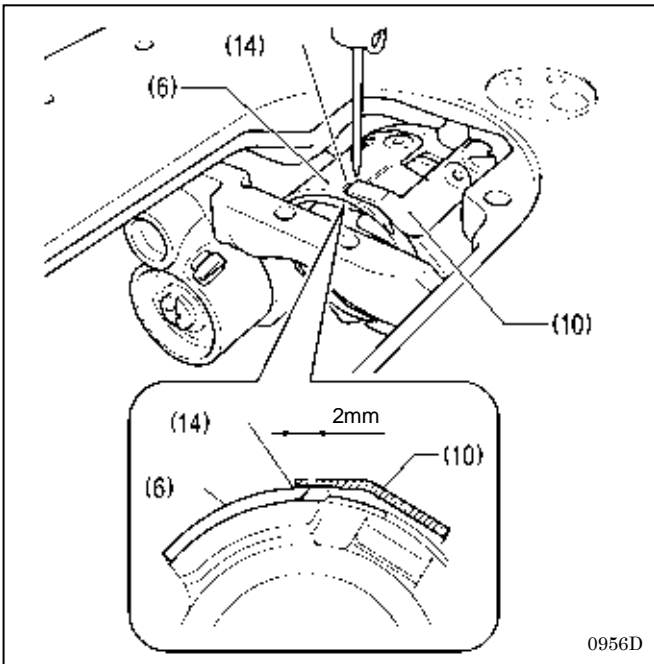

10. Set the maximum meshing amount for the upper and lower knives to 2 mm.

- \* Turn the thread trimmer lever (1) to align the tip of the upper knife (10) with the center of the index mark (14) on the lower knife (6).
- \* Make sure that the tip of the upper knife (10) does not go past the index mark (14).

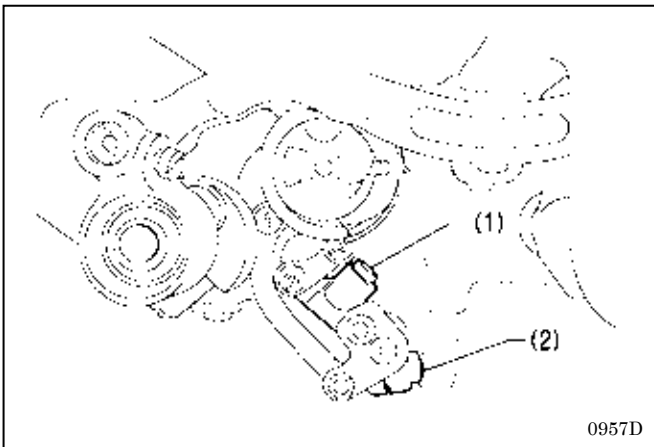

11. Tighten the screw (2) of the thread trimmer lever (1).

- \* Make sure that there is no play in the thrust direction in the forked shaft (15) of the thread trimmer lever (1) (see illustration on page 8).

## 12. STANDARD ADJUSTMENTS

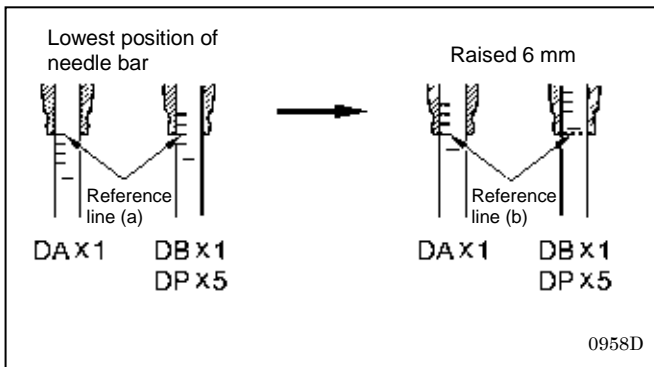

### <Thread trimming cam position adjustment>

1. Turn the machine pulley to raise the needle bar 6 mm from its lowest position (reference line (a) position) so that reference line (b) is aligned with the bottom edge of the needle bar bush.

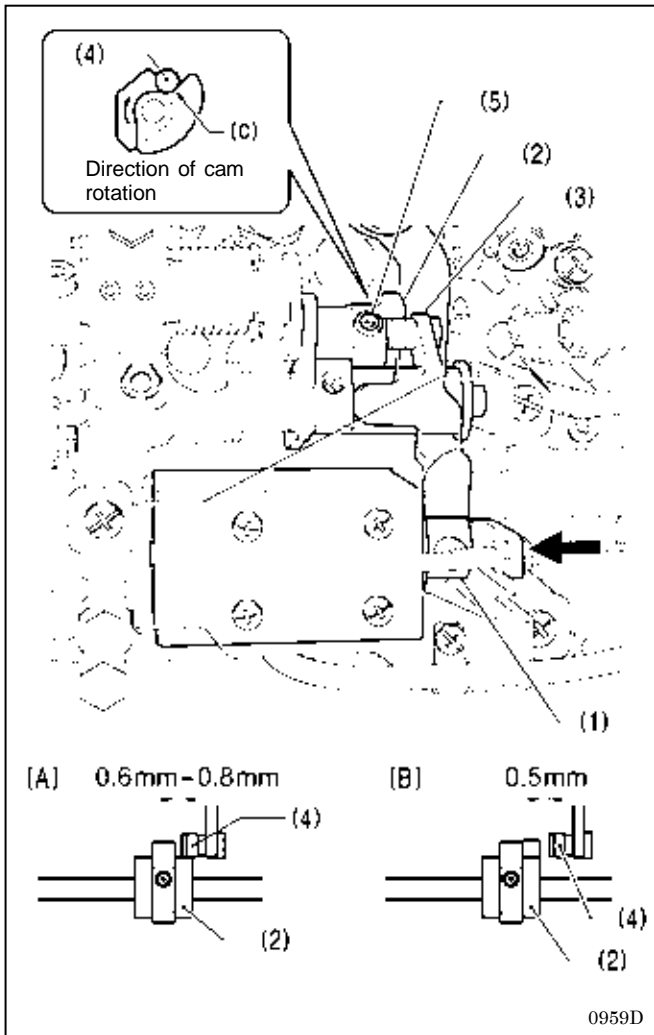

2. At the above position, push the plunger (1) of the thread trimming solenoid with your finger in the direction of the arrow.

Adjust the position of the thread trimmer cam (2) at this time so that the roller shaft (4) of the thread trimming cam lever assembly (3) touches the hollow (c) of the thread trimmer cam (2) and so that the clearance between the edge of the thread trimmer is 0.6 to 0.8 mm. (Fig. A)

3. Check that the clearance between the edge of the thread trimmer cam (2) and the roller shaft (4) is 0.5 mm when the roller shaft (4) returns to the right. (Fig. (B))

\* Tighten the two set screws (5) to approximately 4 N.m.



# 13. LIST OF ERROR CODES

## LIST OF ERROR CODES

If an error code appears on the touch panel display

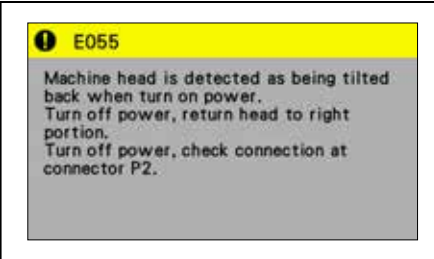

- Items with a "\*" in the "Page" column should only be checked by a qualified technician.
- For items with "\*\*\*" appearing in the "Page" column, ask the place of purchase for advice.

### <Connector layout diagram>

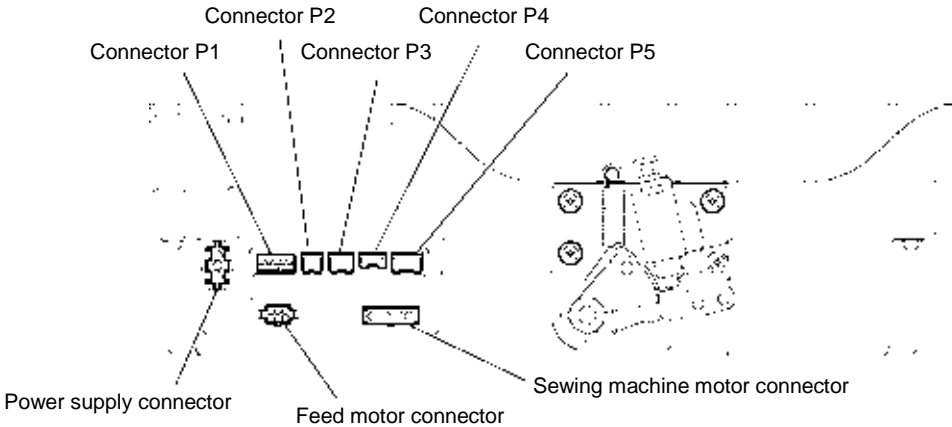

0926D

### Main P.C. board

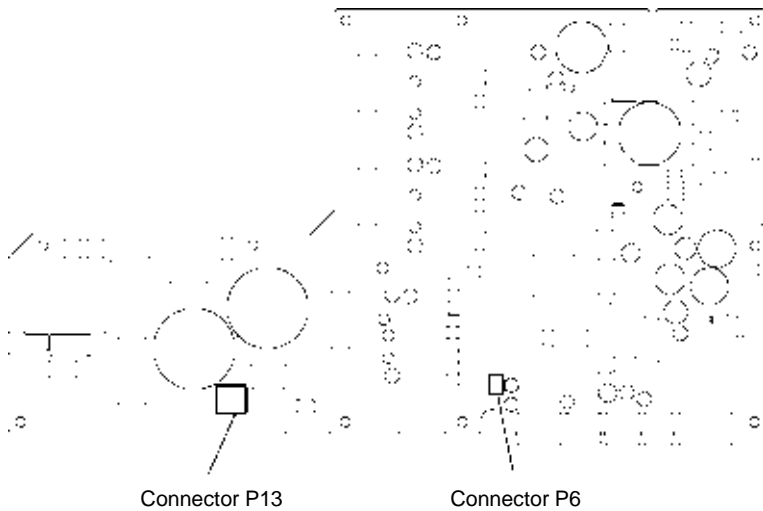

0927D

### 13. LIST OF ERROR CODES

#### Switch-related errors

Code	Cause	Remedy
E050	Machine head is detected as being tilted back when start sewing.	<ul style="list-style-type: none"> <li>• Turn off the power, and then return the machine head to its original position.</li> <li>• Turn off the power and check the connection of connector P2.</li> </ul>
E051	Machine head is detected as being tilted back during sewing.	Turn off the power and check the connection of connector P2.
E055	Machine head is detected as being tilted back when power was turned on.	<ul style="list-style-type: none"> <li>• Turn off the power, and then return the machine head to its original position.</li> <li>• Turn off the power and check the connection of connector P2.</li> </ul>
E064	Touch key was being pressed when power was turned on.	Turn the power off and then back on again. * Do not press the touch keys when turning on the power.
E065	A disabled hardware key was being pressed when the power was turned on.	Turn the power off and then back on again. * Do not press a disabled hardware key while turning on the power.
E066	Hand switch A was being pressed when power was turned on.	Turn the power off and then back on again. * Do not press hand switch A when turning on the power.
E067	Hand switch B was being pressed when power was turned on.	Turn the power off and then back on again. * Do not press hand switch B when turning on the power.
E068	Connection of hand switch A was not detected when power was turned on.	Turn off the power and check the connection of connector P3.
E069	Connection of hand switch B was not detected when power was turned on.	Turn off the power and check the connection of connector P3.
E090	Connection of treadle was not detected when power was turned on.	Turn off the power and check the connection of connector P6.
E095	Treadle or standing operation pedal was being pressed when power was turned on.	Return treadle unit or standing up operation pedal to original portion. * Do not press the treadle or the standing operation pedal when turning on the power.

#### Sewing machine motor-related errors

Code	Cause	Remedy
E100	Time for grease up.	Turn off the power, apply grease, and then clear the grease up counter according to the method specified.
E111	The needle up stop position exceeded the specified value when the sewing machine motor stopped.	Turn off the power and check if the sewing machine motor or thread trimming mechanism is stiff or not.
E112	The needle up or needle down stop position did not reach the specified value when the sewing machine motor stopped.	Turn off the power and check if the sewing machine motor or thread trimming mechanism is stiff or not.
E113	The needle down stop position exceeded the specified value when the sewing machine motor stopped.	Turn off the power and check if the sewing machine motor or thread trimming mechanism is stiff or not.
E130	Sewing machine motor did not operate at sewing start or during sewing.	<ul style="list-style-type: none"> <li>• Turn off the power and check if the sewing machine motor is stiff or not.</li> <li>• Turn off the power and check the connections of the sewing machine motor connector and connector P5.</li> </ul>
E131	Sewing machine motor encoder connection was not detected when power was turned on.	Turn off the power and check the connection of connector P5.
E132	Abnormal sewing speed of sewing machine motor was detected during sewing.	Turn off the power and check the connection of connector P5.
E140	Sewing machine motor ran in opposite direction to the direction specified during sewing.	Turn off the power and check the connection of connector P5.
E150	Abnormal overheating detected in sewing machine motor.	Turn off the power and check the sewing conditions.
E151	Motor overheating sensor connection was not detected.	Turn off the power and check the connection of connector P5.
E161	Sewing machine motor overload was detected during sewing.	Turn off the power and check the sewing conditions.

Code	Cause	Remedy
E190	Sewing machine motor was running continuously for too long during sewing.	Turn the power off and then back on again.
E191	Thread trimming solenoid operation was not completed within the specified period.	Turn off power and check if the thread trimming mechanism is stiff.

**Feed mechanism-related errors**

Code	Cause	Remedy
E210	Feed motor origin is not detected when power is turned on.	<ul style="list-style-type: none"> <li>• Turn off the power and check that the feed mechanism is not abnormal.</li> <li>• Turn off the power and check the feed motor connector and connector P4.</li> </ul>
E211	Abnormal feed motor operation detected during sewing.	<ul style="list-style-type: none"> <li>• Turn off the power and check that the feed mechanism is not abnormal.</li> <li>• Turn off the power and check the feed motor connector and connector P4.</li> </ul>
E251	Abnormal feed motor overheating detected or feed motor overheating sensor was not detected.	<ul style="list-style-type: none"> <li>• Turn off the power and check the sewing conditions.</li> <li>• Turn off the power and check the connection of connector P4.</li> </ul>

**Communication and memory-related errors**

Code	Cause	Remedy
E400	Panel connection was not detected when power was turned on.	Turn off the power and check the connection of connector P2.
E410	Communication error with panel occurred when power was turned on.	Turn off the power and check the connection of connector P2.
E422	Error when reading from USB media.	<ul style="list-style-type: none"> <li>• Press the Reset key.</li> <li>• Check the data in the USB media.</li> </ul>
E424	Insufficient free space in USB media.	<ul style="list-style-type: none"> <li>• Press the Reset key.</li> <li>• Increase the amount of free space in the USB media.</li> </ul>
E425	Error when writing to USB media.	<ul style="list-style-type: none"> <li>• Press the Reset key.</li> <li>• Use the specified USB media.</li> </ul>
E440	Data could not be written to the backup memory (main internal P.C. board).	Turn the power off and then back on again.
E441	Data could not be read from the backup memory (main internal P.C. board).	Turn the power off and then back on again.
E442	Back up memory (main internal P.C. board) data was abnormal, so settings were initialized.	Turn the power off and then back on again.
E450	Model settings could not be read from machine head memory (internal panel).	Turn the power off and then back on again.
E451	Data backup cannot be written to machine head memory (internal panel).	Turn the power off and then back on again.

### 13. LIST OF ERROR CODES

#### P.C. board-related errors

Code	Cause	Remedy
E700	Abnormal rise in power supply voltage was detected when power was turned on.	Turn off the power and check the power supply voltage.
E701	Abnormal rise in sewing machine motor power supply voltage was detected.	<ul style="list-style-type: none"> <li>• Turn off the power and check the power supply voltage.</li> <li>• Turn off the power and check the connection of connector P13.</li> </ul>
E705	Abnormal drop in power supply voltage was detected.	Turn off the power and check the power supply voltage.
E709	Power supply signal could not be detected when power was turned on.	Turn the power off and then back on again.
E710	Abnormal sewing machine motor current was detected.	Turn off the power and check the connection of connector P5.
E711	Abnormal electrical current for feed motor is detected.	Turn off the power and check the connection of connector P4.
E791	Abnormal solenoid mechanism current detected when solenoid was activated.	Turn off the power and check the connection of connector P1.

#### Version updating errors

Code	Cause	Remedy
E880	Version update request could not be received when power was turned on.	Turn off the power and check the connection of connector P2.
E881	Communication error was detected during main version update.	Turn off the power and check the connection of connector P2.
E882	No USB media connected when power was turned on.	Turn off the power and check the connection of the USB media.
E883	Version update file could not be detected in USB media when power was turned on.	Turn off the power and then check that the version update file is contained in the USB media.
E884	Problem with version update file detected during version updating.	Turn off the power, and then repeat the version update procedure.
E885	Version update file could not be read from USB media during version updating.	Turn off the power and check the connection of the USB media.
E886	Problem with version update file detected during version updating.	Turn off the power, and then repeat the version update procedure.
E887	Version update file could not be written during version updating.	Turn off the power, and then repeat the version update procedure.
E888	Error sending or receiving version update file.	Turn off the power, and then repeat the version update procedure.
E889	Incorrect data written to flash memory.	Turn off the power, and then repeat the version update procedure.
E890	Error occurred during version update.	Turn off the power, and then repeat the version update procedure.

If an error code that is not listed above appears or if carrying out the specified remedy does not solve the problem, contact the place of purchase.

# 14. TROUBLESHOOTING

- Please check the following points before calling for repairs or service.
- Simplified details can be checked on the panel. (Menu → Troubleshooting)
- If the following remedies do not fix the problem, turn off the power switch and consult a qualified technician or the place of purchase.

## DANGER







Wait at least 5 minutes after turning off the power switch and disconnecting the power cord from the wall outlet before opening the control box cover. Touching areas where high voltages are present can result in severe injury.

## CAUTION





Turn off the power switch and disconnect the power cord before carrying out these operations. The machine may operate if the treadle is depressed by mistake, which could result in injury.

Items with a "\*" in the "Page" column should only be checked by a qualified technician.

	Problem	Possible cause	Page
1	Upper thread is not tight.  0573M	<ul style="list-style-type: none"> <li>• Is the upper thread tension too weak? Is the lower thread tension too strong? Adjust the lower thread tension or upper thread tension. Try pressing the special locus key and selecting No. 1.</li> </ul>	67 65
2	Lower thread is not tight.  0574M	<ul style="list-style-type: none"> <li>• Is the upper thread tension too strong? Is the lower thread tension too weak? Adjust the lower thread tension or upper thread tension.</li> </ul>	67
3	Loops appear in seam.  0977M	<ul style="list-style-type: none"> <li>• Is the thread path not smooth enough? Use a file with a fine grain or sandpaper to polish smooth the thread path.</li> <li>• Is the bobbin turning smoothly? Pull out the lower thread to check that there is no slackness in the thread tension, or replace the bobbin or bobbin case. Try pressing the special locus key and selecting No. 1.</li> </ul>	65
4	Skipped stitches occur while sewing  0470M	<ul style="list-style-type: none"> <li>• Is the needle tip bent? Is the needle tip blunt? If the needle tip is bent or blunt, replace the needle.</li> <li>• Is the needle properly installed? If it is incorrect, install the needle correctly.</li> <li>• Is the machine properly threaded? If it is incorrect, thread the thread correctly.</li> <li>• Is the presser foot pressure too weak? Adjust the presser foot pressure.</li> <li>• Is the needle too thin? Replace the needle with a needle that is one rank thicker.</li> <li>• Is the presser foot too high? Adjust the height of the presser foot.</li> <li>• Is the thread take-up spring too weak? Adjust the tension of the thread take-up spring.</li> <li>• Is the needle and rotary hook timing correct? Adjust the height of the needle bar.</li> <li>Adjust the clearance between the needle and the tip of the rotary hook.</li> </ul>	16 18 68  75* 74* 78* 80*

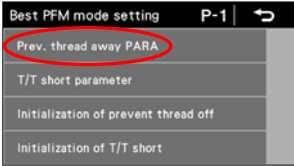
14. TROUBLESHOOTING

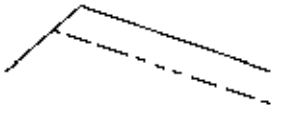
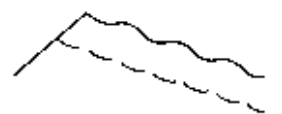
	Problem	Possible cause	Page
5	<p>Skipped stitches at sewing start Thread unraveling at sewing start.</p> 	<ul style="list-style-type: none"> <li>• Is the thread take-up spring tension too strong? Reduce the tension of the thread take-up spring.</li> <li>• Is the thread take-up spring operating range too large? Lower the position of the thread take-up spring.</li> <li>• Is the trailing length of the upper thread too short after thread trimming? Adjust the pretension.</li> <li>• Are the threads not being trimmed cleanly? Sharpen the fixed knives, or replace the fixed and movable knives if necessary. Replace the movable knife.</li> <li>• Is the needle too thick? Replace the needle with a needle that is one rank thinner.</li> <li>• Is the length of thread trailing out from the bobbin case after thread trimming too short If the bobbin is spinning loosely, replace the anti-spin spring in the bobbin case.</li> <li>• Is the sewing speed too fast at the sewing start? Use the slow start key.</li> <li>• Is the needle up stop position too high? Adjust the needle up stop position.</li> <li>• Is the upper thread trailing length too short after thread trimming? Turn on the thread pull-out prevention function.</li> <li>• If the thread is pulling out at the sewing start, try the following remedies.             <ol style="list-style-type: none"> <li>1. Check the upper thread trailing length.</li> <li>2. Set the slow start number to "3" or less.</li> <li>3. Re-adjust the upper thread trailing length to make it longer.</li> <li>4. Keep pressing the best PFM mode key (3), and then select "Prev. thread away PARA" from "Best PFM mode setting".                 <ol style="list-style-type: none"> <li>(1) Set the 2nd stitch pitch to "3".</li> <li>(2) Increase the current stitch pitch settings for the 1st and 2nd stitches by about 0.5 to 1.</li> </ol> </li> </ol> </li> </ul>  <ul style="list-style-type: none"> <li>• Is the needle hole in the needle plate too large for the needle being used? Replace the needle place with one with a needle hole that is one rank thinner.</li> <li>• Is the presser foot groove too wide? Replace the presser foot with one that has a narrower groove so that it presses the material at the needle drop position.</li> <li>• Is the sewing machine starting to sew before the presser foot has dropped? Lower the presser foot before starting sewing.</li> <li>• Is the presser foot being raised before the sewing machine has stopped sewing? Raise the presser foot after the sewing machine has stopped sewing.</li> </ul>	<p>74*</p> <p>74*</p> <p>68</p> <p>82*</p> <p>16</p> <p>21 · 34*</p> <p>32*</p> <p>21 · 35*</p> <p>34*</p> <p>68</p> <p>35*</p>
6	<p>Large bird's nests are forming at the sewing start.</p>	<ul style="list-style-type: none"> <li>• Is the upper thread trailing length too long after thread trimming? Increase the tension of the pre-tension.</li> </ul>	<p>68</p>

	Problem	Possible cause	Page
7	<p>Uneven seam</p>  <p>0473M</p>	<ul style="list-style-type: none"> <li>• Is the presser foot pressure too weak? Adjust the presser foot pressure.</li> <li>• Is the feed dog too low? Adjust the feed dog height.</li> <li>• Is the bobbin scratched? If the bobbin is damaged, smooth it with an oiled grindstone or replace it. Alternatively, replace the bobbin.</li> </ul>	<p>68</p> <p>76*</p>
8	<p>Large degree of puckering (Thread is too tight)</p>  <p>0978M</p>	<ul style="list-style-type: none"> <li>• Is the upper thread tension too strong? Make the upper thread tension as weak as possible.</li> <li>• Is the lower thread tension too strong? Make the lower thread tension as weak as possible.</li> <li>• Is the needle tip blunt? Replace the needle if it is blunt.</li> <li>• Is the needle too thick? Replace with as thin a needle as possible.</li> <li>• Is the thread take-up spring tension too strong? Make the thread take-up spring tension as weak as possible.</li> <li>• Is the thread take-up spring operating range too large? Lower the position of the thread take-up spring to as low a position as possible.</li> <li>• Is the presser foot pressure too strong? Adjust the presser foot pressure.</li> <li>• Is the sewing speed too fast? Gradually reduce the sewing speed.</li> <li>• Is the angle of the feed dog correct? Tilt the front of the feed dog down slightly.</li> </ul>	<p>67</p> <p>67</p> <p>74*</p> <p>73*</p> <p>68</p> <p>23 · 29*</p> <p>77*</p>
9	<p>Lower thread is tangled at the sewing start. Bobbin is spinning during thread trimming.</p>  <p>0751M</p>	<ul style="list-style-type: none"> <li>• Is the bobbin spinning direction correct when the lower thread is being pulled? Set the bobbin so that it turns in the opposite direction to the rotary hook.</li> <li>• Is there too much thread wound onto the bobbin? The bobbin winding amount should not be more than 80%.</li> <li>• Is the anti-spin spring attached? Attach the anti-spin spring.</li> <li>• Is the bobbin turning smoothly? If the bobbin is not turning smoothly, replace the bobbin.</li> <li>• Is a bobbin other than the light-alloy bobbins specified by Brother being used? Use only bobbins which are specified by Brother.</li> </ul>	<p>17</p> <p>17</p> <p>16</p> <p>16</p>

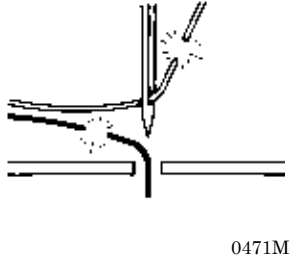
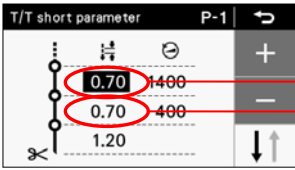

14. TROUBLESHOOTING

	Problem	Possible cause	Page
10	<p>Upper and lower threads are breaking.</p>  <p>0471M</p>	<ul style="list-style-type: none"> <li>• Is the needle tip bent? Is the needle tip blunt? If the needle tip is bent or blunt, replace the needle.</li> <li>• Is the needle properly installed? If it is incorrect, install the needle correctly.</li> <li>• Is the machine properly threaded? If it is incorrect, thread the thread correctly.</li> <li>• Is the rotary hook sufficiently lubricated? If the oil gauge is down to the lower reference line in the oil gauge window, add more oil.</li> <li>• Is the upper or lower thread tension too weak or too strong? Adjust the upper thread or lower thread tension.</li> <li>• Is the upper thread may be loose because the thread take-up spring operating range is too small? Adjust the position of the thread take-up spring.</li> <li>• Is the rotary hook, feed dog or other part damaged? If the thread path is damaged, smooth it with sandpaper or similar. Alternatively, replace the damaged part.</li> <li>• Is the thread path damaged? If the thread path is damaged, smooth it with sandpaper. Alternatively, replace the damaged part.</li> </ul>	<p>16</p> <p>18</p> <p>7</p> <p>67</p> <p>73*</p> <p>*</p> <p>*</p>
11	<p>Thread breaks during backtack sewing.</p>	<ul style="list-style-type: none"> <li>• Is the backtack sewing speed too fast? Use the panel to reduce the backtack sewing speed.</li> </ul>	<p>28 · 30</p>
12	<p>Backtack sewing pitch varies depending on the sewing direction. Backtack edge is not aligned.</p>	<p>Adjust using MSW-201.</p>	<p>51*</p>
13	<p>Thread tightening around X-over seam areas.</p>	<ul style="list-style-type: none"> <li>• Is the height of the feed dog correct? Increase the feed dog height.</li> </ul>	<p>76*</p>
14	<p>Upper thread is pulling out of the needle after thread trimming.</p>	<ul style="list-style-type: none"> <li>• Is the upper thread trailing length after thread trimming appropriate? Decrease the tension of the pre-tension.</li> <li>• Is the thread path not smooth enough? Use a file with a fine grain or sandpaper to polish smooth the thread path.</li> <li>• Does the thread being used slip easily? Turn the needle bar bush thread guide D sideways to increase the resistance.</li> <li>• If the upper thread is pulling out of the needle after thread trimming, check using the method given below.               <ol style="list-style-type: none"> <li>1. Check the upper thread trailing length.</li> <li>2. Re-adjust the upper thread trailing length to make it longer.</li> <li>3. Keep pressing the best PFM mode key, and then select "T/T short parameter".                   <ol style="list-style-type: none"> <li>(1) Delete the stitch pitch for the previous stitch.</li> <li>(2) Decrease the sewing speed for the final stitch and the stitch before it.</li> </ol> </li> </ol> </li> </ul> 	<p>68</p> <p>68</p> <p>35*</p>

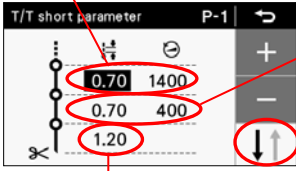

	Problem	Possible cause	Page
15	Upper thread is raised above the material surface after thread trimming.	<ul style="list-style-type: none"> <li>Upper thread protrudes from the material surface after thread trimming.               <ol style="list-style-type: none"> <li>Increase the pitch during thread trimming.</li> <li>Set the feed direction for sewing end processing to ↑.</li> </ol> </li> </ul> <p>Stitch pitch and sewing speed for stitch before final stitch</p>  <p>Stitch pitch and sewing speed for final stitch</p> <p>Feed direction for sewing end processing</p> <p>Stitch pitch during thread trimming</p>	35*
16	When T/T short is on, skipped stitches occur where they should be sewn at the sewing end.	<ul style="list-style-type: none"> <li>Use the T/T short parameters to delete the the stitch before the final stitch.</li> <li>Use the T/T short parameters to reduce the stitch pitch of the final stitch and the one before it.</li> <li>Use the T/T short parameters to set the feed direction for sewing end processing to ↑.</li> </ul> <p>If sewing backtack stitches</p> <ul style="list-style-type: none"> <li>Reduce the number of stitches (D) for backtack sewing by 1 stitch</li> </ul>	35* (94-15)  30*
17	When T/T short is on, condense stitches (the final stitch and the one before it) cannot be sewn neatly before thread trimming.	<ul style="list-style-type: none"> <li>Use the T/T short parameters to increase the stitch pitch.</li> <li>Use the T/T short parameters to reduce the sewing speed.</li> </ul>	35* (94-15)
18	Thread trailing length on underside of material is too long.	<ul style="list-style-type: none"> <li>Turn on the T/T short function.</li> </ul> <p>If you would like the trailing length to be even sorter after turning on the T/T short function.</p> <ul style="list-style-type: none"> <li>Is the meshing position of the thread trimming knives directly below the needle hole?</li> <li>Use the T/T short parameters to reduce the stitch pitch of the condense stitches (the final stitch and the one before it) before thread trimming.</li> <li>Use the T/T short parameters to reduce the pitch during thread trimming.</li> </ul>	35*  82*  35* (94-15)
19	When T/T short is on, thread trailing length on underside of material is too short.	<ul style="list-style-type: none"> <li>Use the T/T short parameters to increase the pitch during thread trimming.</li> </ul>	35* (94-15)
20	To prevent fraying at the sewing end	<ul style="list-style-type: none"> <li>Turn on the T/T short function, and then use the T/T short parameters to set the feed direction for sewing end processing to ↑.</li> </ul>	35* (94-15)
21	Incorrect thread trimming (Upper and lower threads are both not being trimmed)	<ul style="list-style-type: none"> <li>Is the fixed knife or movable knife damaged or worn? Replace the fixed knife or the movable knife.</li> <li>Is there not enough of a meshing amount between the upper knife and the lower knife? Adjust the tip of the upper knife to the lower knife index position so that the knives mesh.</li> </ul>	82*

## 14. TROUBLESHOOTING

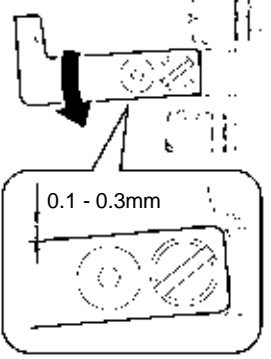
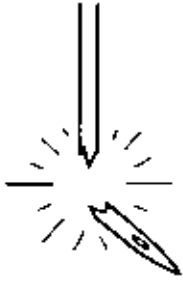
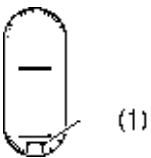
	Problem	Possible cause	Page
22	<p>Incorrect thread trimming (Upper thread is not being trimmed.) (Lower thread is not being trimmed.)</p>  <p>0949D</p>	<ul style="list-style-type: none"> <li>• Is the needle properly installed? If it is incorrect, install the needle correctly.</li> <li>• Is the fixed knife or movable knife blunt? Replace the fixed knife or the movable knife.</li> <li>• Tilt the upper knife forward slightly. (About 0.1 to 0.3 mm)</li> <li>• Is there not enough of a meshing amount between the upper knife and the lower knife? Check that the tip of the upper knife comes to the lower knife index position so that the knives mesh.</li> </ul>	16 82*
23	<p>Broken needle</p>  <p>0469M</p>	<ul style="list-style-type: none"> <li>• Is the material being pushed or pulled with excessive force during sewing?</li> <li>• Is the needle properly installed? If it is incorrect, install the needle correctly.</li> <li>• Is the needle tip bent? Is the needle tip broken, or is the needle hole blocked? Replace the needle.</li> <li>• Is the needle and rotary hook timing correct? Adjust the height of the needle bar. Adjust the clearance between the needle and the tip of the rotary hook.</li> <li>• Is the needle and feed mechanism timing correct? Adjust to the standard timing.</li> <li>• Try pressing the special locus key and selecting No. 2 or No. 3.</li> </ul> <p><b>NOTE:</b></p> <ul style="list-style-type: none"> <li>• It is extremely dangerous to leave any pieces of broken needle sticking in the material. If the needle breaks, search for all pieces until the whole of the needle is found again.</li> <li>• Furthermore, we recommend that thorough steps be taken to account for such needles to comply with product liability regulations.</li> </ul>	16 80* * 79* 65
24	<p>Oil gauge (1) is not visible in oil gauge window.</p>  <p>0923D</p>	<ul style="list-style-type: none"> <li>• Is the oil tank empty? Fill the oil tank with oil.</li> </ul>	7
25	<p>The presser foot does not lift using the knee lifter.</p>	<ul style="list-style-type: none"> <li>• Is the knee lifter being used at the needle up position while thread trimming is disabled? Enable thread trimming.</li> <li>• Is the knee lifter being used before the sewing machine has stopped? Adjust the tension release switching plate upward to retard the tension release timing.</li> </ul>	
26	<p>Thread take-up spring stopper and thread take-up spring are twisted together.</p>	<ul style="list-style-type: none"> <li>• Adjust the tension release switching plate upward to retard the tension release timing.</li> </ul>	

	Problem	Possible cause	Page
27	Machine does not operate when power is turned on and treadle is pressed.	<ul style="list-style-type: none"> <li>• Is the power supply connector disconnected from the control box? Insert the connectors securely.</li> <li>• Is the operation panel set to a screen other than a screen where sewing is possible? Switch the operation panel to a screen where sewing is possible, such as the home screen.</li> </ul>	<p>12 · 13</p> <p>61</p>
28	Machine does not operate at high speed.	<ul style="list-style-type: none"> <li>• Is the sewing speed setting or backtack stitch speed setting too slow? Set a higher sewing speed.</li> </ul>	28 - 30
29	Machine stops during sewing.	<ul style="list-style-type: none"> <li>• Has the sewing pattern been set to a fixed stitch pattern? In main sewing mode, set the sewing pattern to something other than a fixed stitch pattern.</li> <li>• Is the power supply voltage too low? Check the power supply voltage. (If the power cord is too long or too many appliances are being run from a single outlet, this may cause voltage drops which will in turn cause the reset function to activate and stop the machine, even if the power supply itself is normal.)</li> </ul>	<p>25 · 29</p> <p>*</p>
30	Nothing appears on the operation panel display.	<ul style="list-style-type: none"> <li>• Is the power supply connector disconnected from the control box? Insert the connectors securely.</li> <li>• Is the operation panel connector inside the control box disconnected? Insert the connectors securely.</li> </ul>	<p>12 · 13</p> <p>8</p>
31	"Grease up" flashes in the panel display when the power switch is turned on.	<ul style="list-style-type: none"> <li>• This display is to notify you that it is time to apply grease. Apply grease.</li> </ul>	*

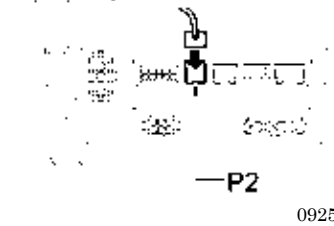
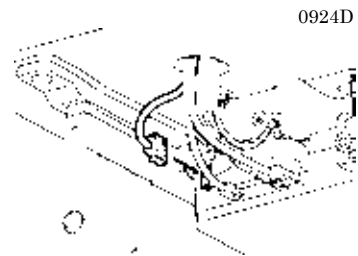
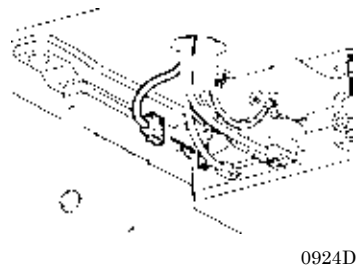

# brother

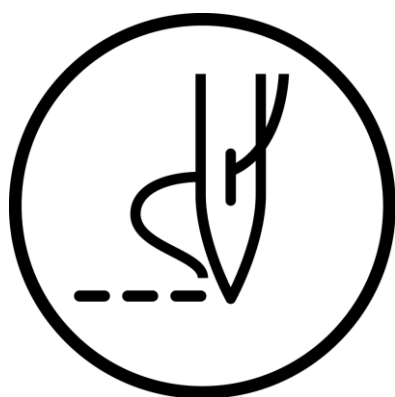

## INSTRUCTION MANUAL

\* Please note that the contents of this manual may differ slightly from the actual product purchased as a result of product improvements.

**BROTHER INDUSTRIES, LTD.** <http://www.brother.com/>  
1-5, Kitajizoyama, Noda-cho, Kariya 448-0803, Japan. Phone : 81-566-95-0088

© 2015 Brother Industries, Ltd. All Rights Reserved.  
This is the original instructions.

S-7300A  
I5031041D  
2015.03. D(1)